

GREEN MOWER
LM22GF
LM26GF

TEERING GROUND MOWER
LM26TF

BARONNESS

LAWN MOWER

22-8-00

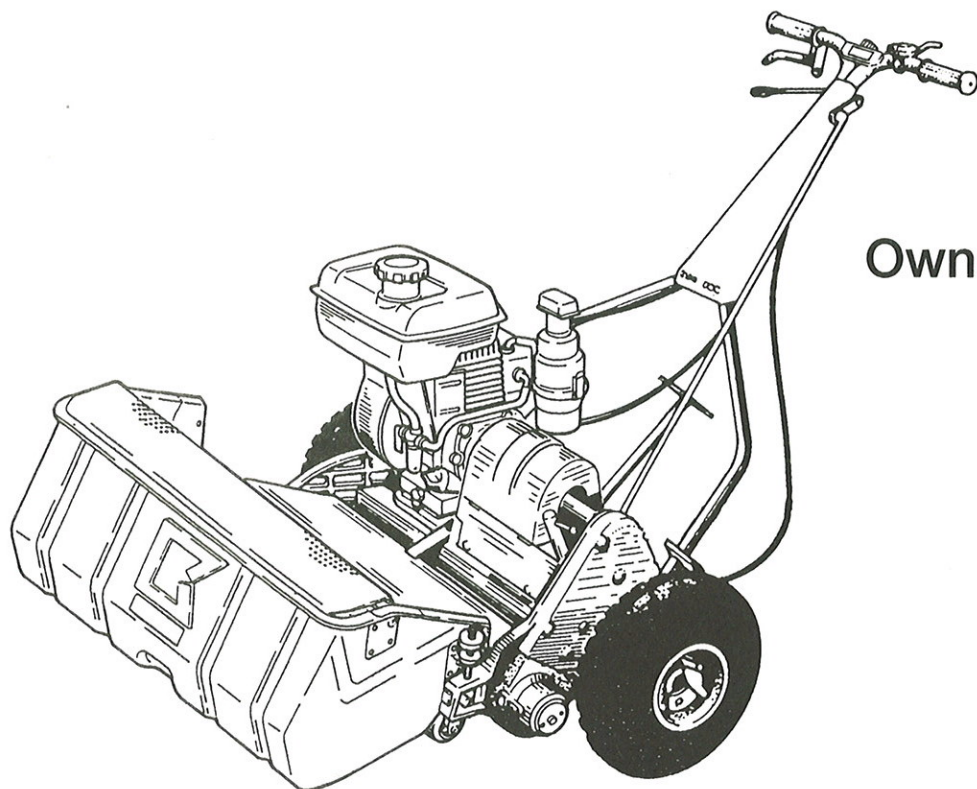

Owner's Handling Manual & Parts Catalog

Read this manual before using the machine.

BARONNESS

CONTENTS

CONTENTS	1
Warning for Safety	2
Greeting	2
Owner's Handling Manual	2
1. Part names	3
2. Specifications	4
3. Features	4
4. Assembly/adjustment of main unit	5
5. Inspection before use	6
6. Fastening of each portion	6
7. Engine starting sequence	6
8. Machine operation	6 • 7 • 8 • 9
9. Blade engagement	9 • 10 • 11
10. Long-term storage	11
11. Precautions for engine operation	12
12. Special optional parts	12 • 13

Parts Catalog	14
1. Engine clutch stand	15 • 16
2. Drum wheel	17 • 18
3. Blade reel cylinder/front roller/bottom blade	19 • 20
4. Frame/transmission	21 • 22
5. Handle/engine	23 • 24
6. Accessory parts	25 • 26
7. Internal expanding brake parts	27 • 28
8. LM22GE/26GE dethatching reel (Option)	29 • 30
9. Sweeping brush (Option)	31 • 32

Warning for Safety

Warning marks indicate important items for safety.
Observe them strictly.

Warning Marks



Negligence of the warning will cause death or serious injury.

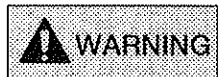

Negligence of the warning may cause death or serious injury.

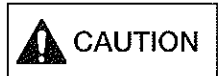

Negligence of the warning may cause injury.

Symbols



See the Handling Manual



Engine switch lever



Fuel : Gasoline



Hot surface
Burn on hand



Danger mark
Hand cut



Danger mark
Foot cut



10h

Grease
Every 10hours



CAUTION : Joint shaft

Greeting

Thank you very much for purchasing BARONESS GREEN MOWER and TEEING GROUND MOWER.

This Owner's Handling Manual explains the method of correct handling, adjustment, and maintenance of the mower. Thoroughly read the manual before operation. Carefully read the engine operation manual before starting the engine. Mowers undergo thoroughgoing trial operation and inspection before shipment. However, whether or not the mower can exhibit the expected performance depends on the handling method, inspection/adjustment before and after operation, and the properness of lubrication. Handle the mower correctly for safe and excellent operation for an extended period of time.

Owner's Handling Manual

Precautions:

- The name of the model may be different when you make an inquiry about your machine. Advise us of the machine number as well.
- The contents of this manual are subject to change without notice.



CAUTION

The warning marks attached to the machine indicate precautions for safety. Read them carefully. Understand well the operating procedures and safety precautions before using the machine. The marks and explanatory notes should be kept clean. If they are lost or damaged, attach new marks.

1. Part names

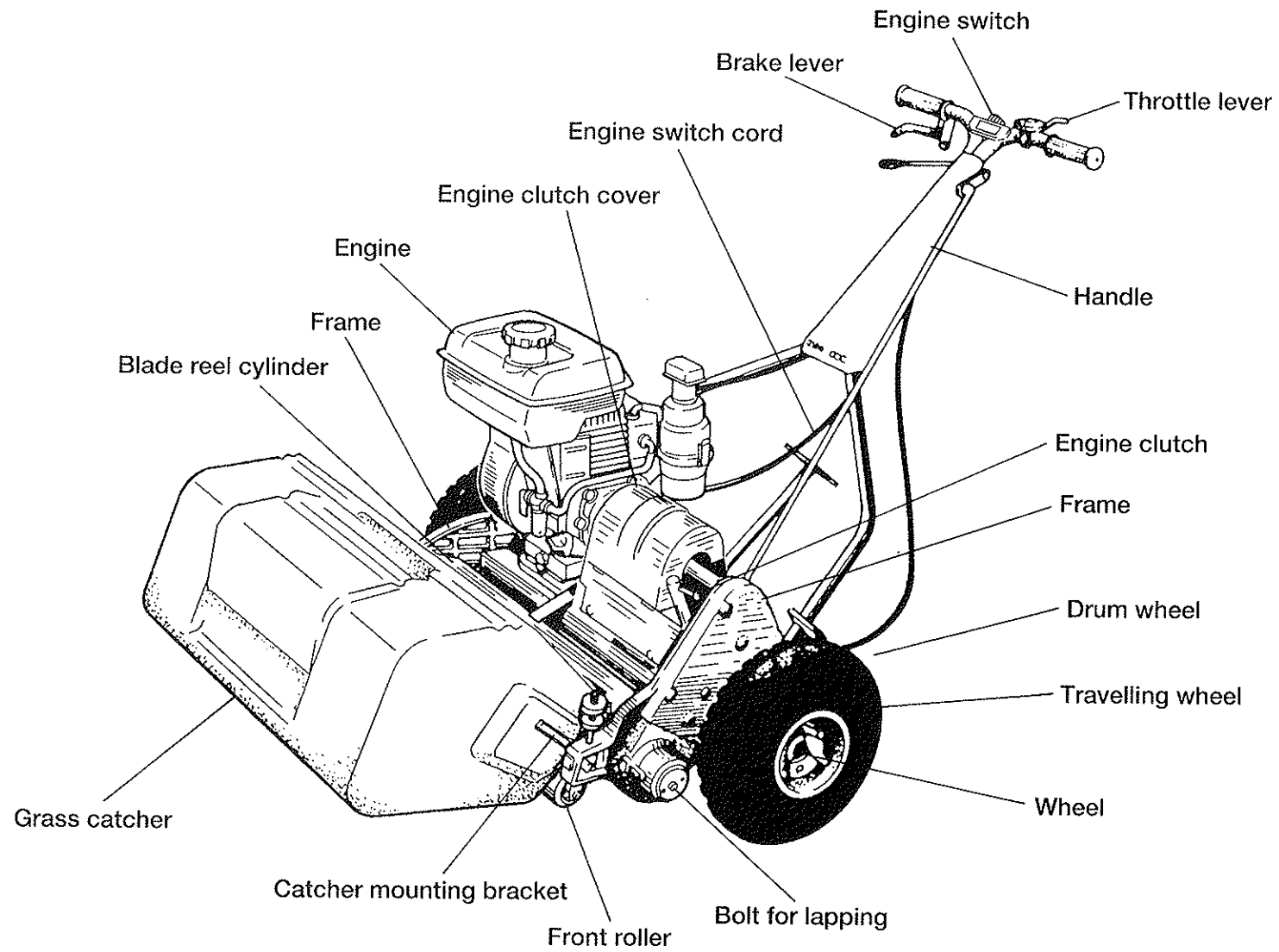

2. Specifications

2-1. Main unit



The engine brake will not work. Use a carrier or truck to move the mower.

	LM22GF	LM26GF	LM26TF
Length (cm)	135	←	←
Width (cm)	91	100	←
Height (cm)	111	←	←
[Weight] During operation (kg)	84.3	89	←
[Weight] Grass catcher	3.2	3.8	←
[Mowing section] Mowing width (cm)	55.6	64.6	←
[Mowing section] Reel dia. (cm)	φ 12.8	←	←
[Mowing section] Number of reel blades *	9 *	←	7
Frame	Aluminum alloy	←	←
Front roller (cm)	φ 6×57.7	φ 6×66.6	←
Drum wheel (cm)	Steel pipe drum φ 19.6×53.5	Steel pipe drum φ 19.6×62.5	Aluminum drum φ 20.3×62.5
Speed (km/h)	5	←	4.3
Engine	ROBIN EY15D K9270000020		←

- The weight excludes the travelling wheel (6.4 kg) and grass catcher.
- The above speed is available when the engine is rotating at 3000 rpm.
- * 11-blade reel cylinder available as an option.

3. Features

- 3-1. The handle is provided with an engine switch for safe operation.
- 3-2. The coil spring makes uniform the preload applied to the tapered bearing by the blade reel cylinder, ensuring stable rotation and facilitating adjustment.
- 3-3. These mowers are the lightest of all models in this class, permitting easy operation.
- 3-4. The blade reel cylinder made of specially-blended heat treated steel cuts well and excels in durability.

4. Assembly/adjustment of main unit

4-1. Fit the handles into the handle pins on both sides of the frame, respectively, in order of (a), (b), and (c).

- Fit the handle mounting pin R (4-61) on the left frame (4-1) into the hole at the front end of the handle. ←
- Pull the right edge of the handle toward the inside. ←
- Fit the handle pin L (4-85) on the right frame into the hole at the right front end of the handle. →

※ Adjust the clutch rod according to the height of the handle.

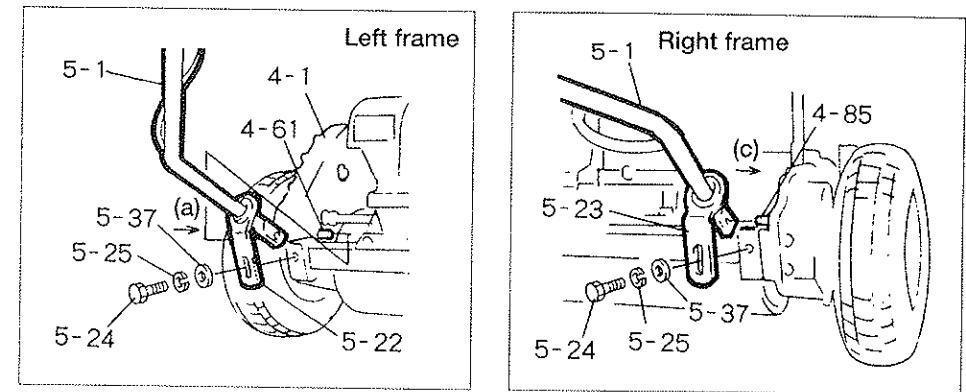

4-2. Installation of stand

Hook the U-shaped portion of the spring on the pin using a tool to install the stand.

4-3. Installation and adjustment of clutch rod

Install the clutch rod with a snap pin. Make adjustment according to the height of the handle until the clutch operates perfectly.

4-4. Connection of engine switch cord

Connect the engine switch cord during installation of the handle. Connect two positions - the plug and the terminal.

- Connect the plug with the plug connected to the front of the engine.
- Loosen the bolt at the front of the engine, insert the terminal, and tighten the bolt. (See the figure at right.) Be sure to connect the engine switch cord, otherwise the engine will not stop.

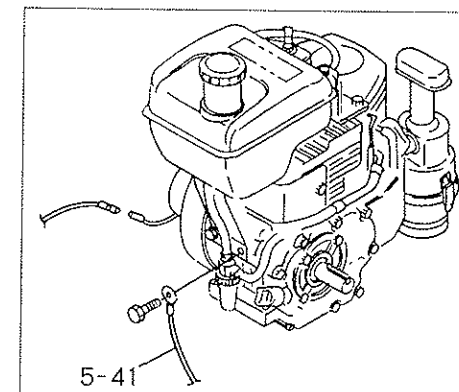
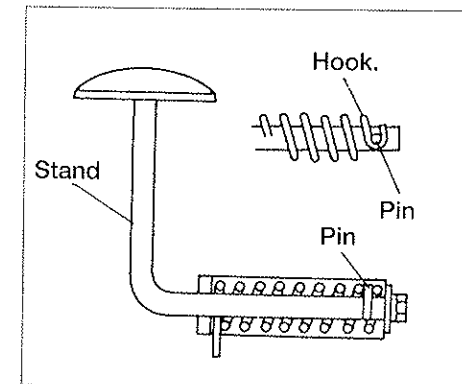

5. Inspection before use

5-1. Greasing



The transmission and intermediate transmission gears are equipped with needle bearings. Grease them every 10 hours. Shortage of grease will cause heat generation and a grating sound.

5-2.

Replenish the engine with engine oil. (A correct level will be shown when the engine is placed horizontally.) Change engine oil 5 hours after the initial operation, and every 50 hours from the second time onward. Oil : SAE30.

6. Fastening of each portion

Many parts are fastened by bolts. Bolts and nuts may be loosened some time after initial operation. Fasten them to the specified torque.

Appropriate fastening torque (kgf-cm)

	Normal bolt	Heat treated bolt
M6	80	
M8	180	360
M10	360	720
M16	1.5-pitch left-hand thread: 360 kgf-cm	

7. Engine starting sequence



7-1. Before starting engine

Carefully read the gasoline engine operation manual before starting the engine. Check the ON/OFF positions of the engine switch lever at the front of the handle. Set the engine switch lever in the ON position, set all moving parts in the neutral position. Check for safety - covers are in position and not damaged and there is no person around the machine - before starting the engine. Do not start the engine indoors without an appropriate ventilator.

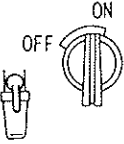
7-2. Starting the engine

- (1) Set the clutch lever in the OFF position. (See 9-2.)
- (2) Set the throttle lever in the high-speed  position.
- (3) Set the engine switch lever in the ON position. 
- (4) Set the strainer lever in the open position.
- (5) Pull the choke lever and pull the recoil starter, and the engine will start.
- (6) Return the choke lever.

7-3. Stopping the engine (Remember the method for stopping the engine in an emergency.)

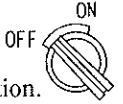
- (1) Set the clutch lever in the OFF position.
- (2) Set the throttle lever in the slow-speed  position.
- (3) Set the strainer lever in the close position. 
- (4) Set the engine switch lever in the OFF position. 
- (5) In an emergency, immediately set the engine switch in the OFF position.

7-4. Fuel supply Gasoline for automobiles

- (1) Keep flame etc. away from the engine when supplying fuel. Stop the engine outdoors and allow it to cool before supplying fuel.
- (2) Keep the machine clean at all times to prevent deposition of dust, grease, or oil.

7-5. When leaving the machine

Park the machine on a flat place. Check that the engine switch lever is in the OFF position. Do not park the machine on a slope.

8. Machine operation

8-1.

Check that each portion - especially the brake and clutch - operates satisfactorily before starting machine operation. Make sure that the machine can be stopped immediately at any time. Exercise care so that you and people around the machine will not be injured.

8-2. Travelling lever

The travelling lever is provided at right in front of the handle. Push it forward, and it will enter the OFF position and stop. Pull it to your side, and it will enter the ON position, and the machine begins to travel. Move the lever slowly.

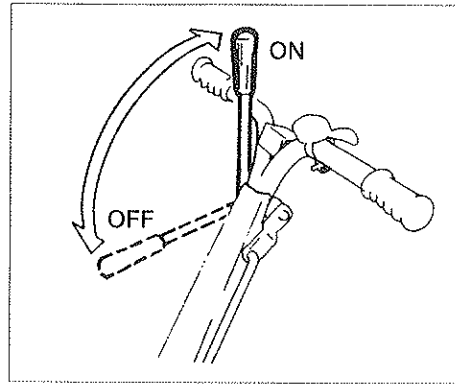

8-3. Clutch lever

The mower clutch lever is provided in the lower front position at left. Set it in the ON and OFF positions for engagement and disengagement, respectively. Set it in the OFF position when moving the machine.

8-4. Adjustment of handle height

Move the handle guide plates (5-22 and 5-23) vertically to change the height of the handle according to the height of the operator. Adjust the length of the clutch rod simultaneously. Make adjustment so that the clutch spring will completely enter the clutch when the clutch is engaged.

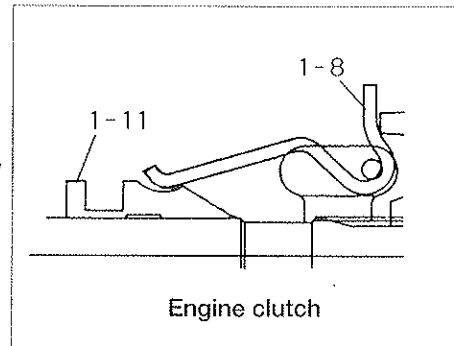

8-5. WARNING Brake lever

The brake lever is provided at right. Grip the lever, and the brake drums set on the right and left drum shafts operate simultaneously. If the braking performance is nonuniform, make adjustment for uniform operation.

8-6. Throttle lever

The throttle lever is on the left side of the handle. The lever controls the engine speed. The adjustment range is 1350-3300 rpm. The engine speed should be 3000 rpm for mowing operation.

8-7. [IMPORTANT] Adjustment of engine clutch

(1) When reinstalling the engine:

Adjust the clearance between the engine clutch and clutch facing so that it will be approx. 0.5 mm when the travelling clutch is engaged. For adjustment, loosen the four bolts that are securing the engine, and insert a thickness gauge (attached) into the front and rear. Make adjustment so that the gap will be parallel, and then fasten the bolts.

(2) After using a new machine for 10 hours or when the clutch spring is changed:

Make adjustment so that the difference in the position of the clutch plate when the clutch is engaged and disengaged will be 0.8-1 mm.

Loosen the bolt (1-10) that is securing the lever mounting base (1-7), screw in the base up to an appropriate position, and then secure the base with the bolt. (See the figure below.)

Apply grease sufficiently to the clutch and clutch mover, and check them every 10 hours.

Adjust the clutch mover so that it will be in the center of the clutch when the clutch is engaged.

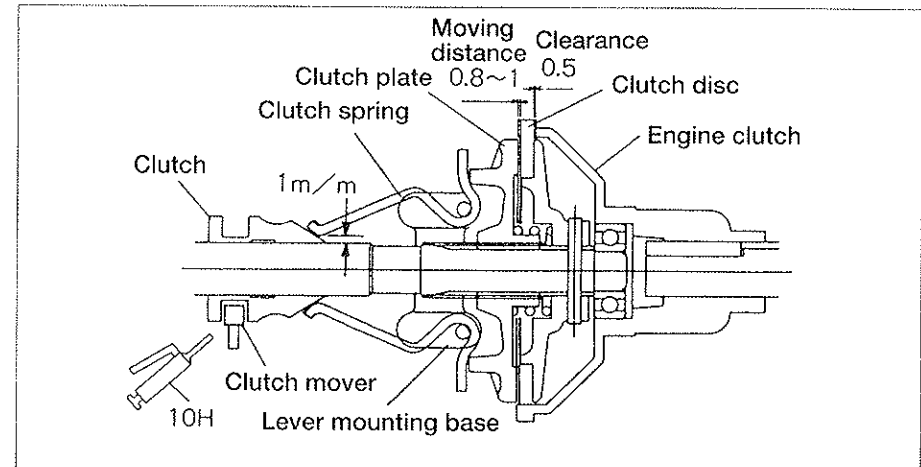

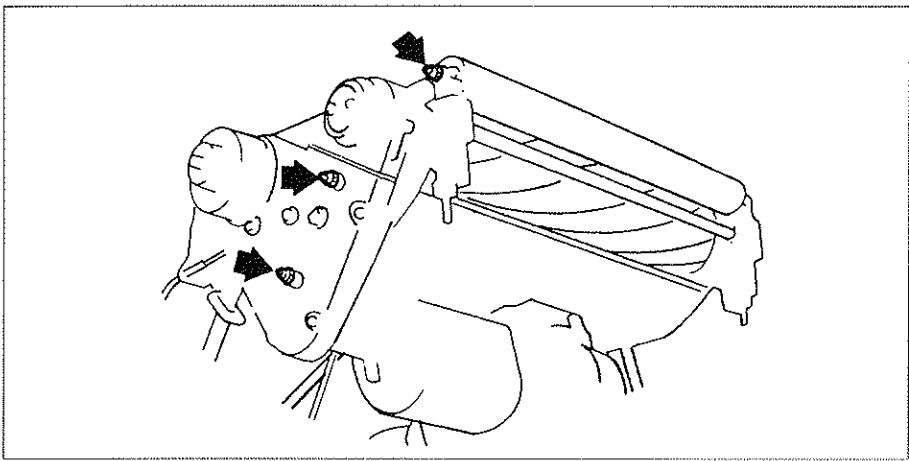

- Engine clutch and clutch mover
 - Differential gear section
 - Intermediate shaft on left frame
 - 2 shafts on left frame
- Every 10 hours →
exercise care when greasing them.

Fill up grease nipples with approx. 1g of grease (EXCELITE EP NO.2) every 10 hours—one or two times injection with a small manual grease pump. Needle bearings are used, so

8-12. [IMPORTANT] Greasing

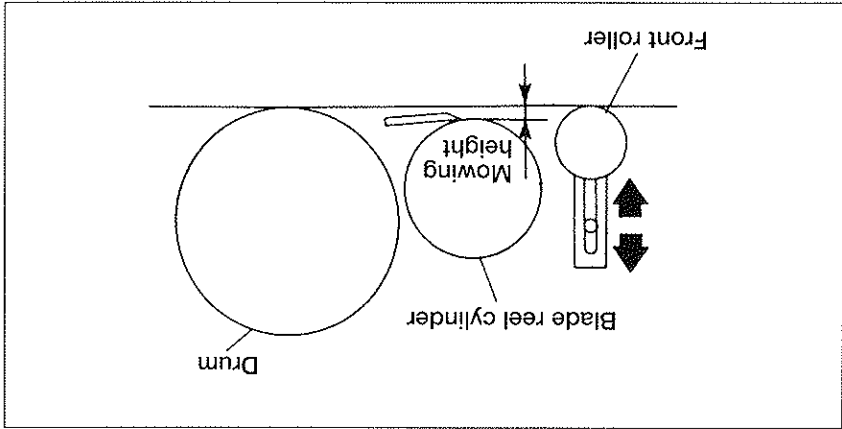

The clutch cover is on the left side of the engine, covering the engine clutch. It is secured by turning the wing bolt clockwise (by 4-5 turns).

8-8. Clutch cover

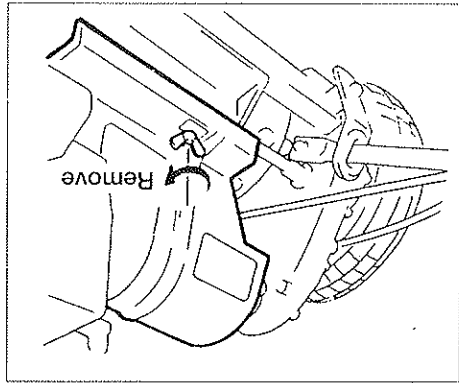

The travelling wheel is used to move the machine from green to green. Set the stand upright, hold and pull the tire and lever, and the wheel will come off.

8-9. Travelling wheel

8-10. [IMPORTANT] Adjustment of clutch rod lever

Be sure to adjust the rod length after adjusting the handle height.

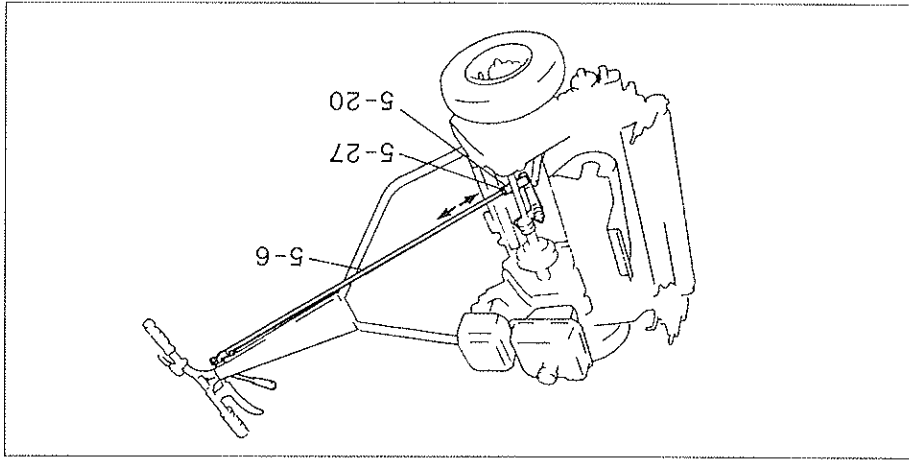

8-11. [IMPORTANT] Adjustment of mowing height

Move the front roller up or down, and the mowing height can be adjusted within the range of 4-19 mm. Use an optional bottom blade when 3 mm mowing height is desired.

8-13. Setting the mowing height gauge

(1) Set the mowing height gauge at the desired height. The minimum mowing height with respect to each bottom blade thickness is shown below. (The maximum height is 19 mm.)

Blade thickness (mm) Min. mowing height (mm)	Green	Teeing ground
Standard blade: 2.5	3.5	
Special No.2 for tournament: 1.8	3.0	
High-speed-steel-tipped blade: 3.0	4.0	
Standard tipped blade: 5.0	7.0	

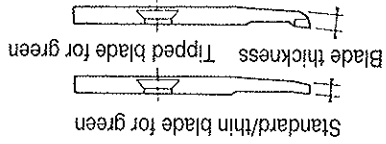

※ The minimum mowing height is the average height on the green. Lawn may be shaved when the undulation of the green is substantial. Set the mowing height slightly higher in that case.

(2) When the mowing height of 7 mm or less is desired for the teeing ground, use the green mower bottom blade.

and blade thickness

9. Blade engagement

Grind and adjust the blade reel cylinder and bottom blade entirely so that a newspaper will be cut sharply.

- 9-1. [IMPORTANT] Lapping
- Conduct lapping after mowing operation (before adjusting the engagement).
- (1) Check the entire portion of the blade reel cylinder to check which portion is dull. (If a newspaper cannot be cut in any portion, put in two sheets of paper to carefully check which portion is dull.)
 - (2) Connect the lapping machine (RM20) or lapping handle (option) to 10 special bolt 35 (Parts Catalogue No.4-72) of the machine.

[IMPORTANT] Adjustment of front roller height

- (1) Loosen the tail nut of the roller bracket, and move the front roller up or down with the mowing height adjusting screw.
- (2) Position the front roller with the mowing height gauge.
- (3) Make adjustment at both edges.
- (4) Tighten the tail nut, and secure the roller bracket.

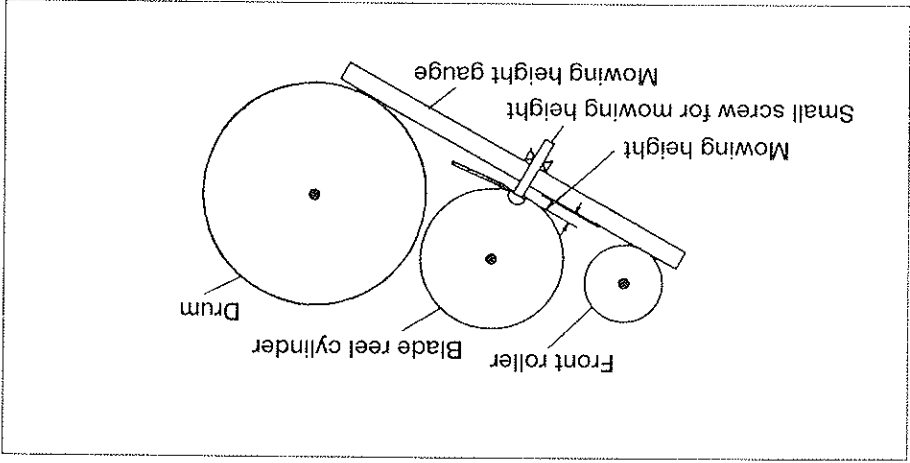

(3) Rotate the blade reel cylinder in the direction opposite to the mowing direction, and apply abrasive with a brush only to the portion where a newspaper was sharply cut. The portion where a newspaper was not cut is worn away. Do not apply abrasive to such portions.

※ The right side (when viewed from the front of the blade reel cylinder) of the blade reel cylinder will be worn away 3-4 times earlier than the left side. When applying abrasive to the blade reel cylinder, be sure to move the brush from left to right. (Fig.7)

(4) Keep rotating the blade reel cylinder, and stop rotation when the contact sound disappears. Put in a newspaper again to check the blade reel cylinder entirely for the sharpness of each portion.

(5) Repeat operations (3) and (4). When the blade reel cylinder and bottom blade are in contact with each other uniformly, apply abrasive to the blade reel cylinder entirely for final lapping.

(6) After lapping, remove the abrasive with steam, etc.

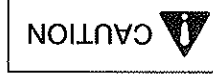

Both blade reel cylinder and bottom blade are edged. Handle them carefully.

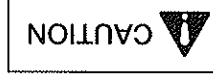

Be careful of the fingers, which turn the blade reel cylinder, when cutting a newspaper to check sharpness. Uniformly lap the right and left sides of the bottom blade in contact with the blade reel cylinder, and the life of the blade will be maximized.

9-2. [IMPORTANT] Engagement

(1) Lightly engage the blade reel cylinder and bottom blade uniformly on both sides. (a) Uniformly adjust the bottom blade on the right and left sides. Turn the cutter adjuster (3-37) clockwise for slight engagement, and turn it counterclockwise for firm engagement. (Fig.8)

(b) Lightly engage both sides to the extent that a newspaper will be cut sharply.

When the blade reel cylinder is worn away and the spring pressure decreases, loosen the lock nut (3-44) and turn the threaded pipe (3-39) clockwise, and the spring pressure will increase. (Fig.8)

After the green mower is used for one season, the diameter of the blade reel cylinder and the thickness of the bottom blade will decrease by approx. 1 mm on average, respectively.

The thread pitch of the threaded pipe is 1 mm. Turn the threaded pipe clockwise by two turns, and appropriate spring pressure will be maintained. Use the above as guidelines.

9-3. [IMPORTANT] Cam adjustment

Turn the cam bush on both sides of the bottom blade, and the blade will be raised and lowered within a maximum range of 0.3 mm. (Fig.9)

The above method is used when the edges of the blade reel cylinder and bottom blade are not in parallel.

the bottom blade

(1) When there is a gap between the blade reel cylinder and the left frame side of the bottom blade
 (a) Loosen the lock nut, and turn the left cam bush clockwise as much as the gap. Turn it clockwise by 30° to raise the bottom blade by 0.1 mm.
 (b) After adjustment, firmly fasten the lock nut.

(2) When there is a gap on the right frame side, loosen the lock nut, and turn the right cam bush counterclockwise as much as the gap.

9-4. Cylindrical grinding and installation of blade reel cylinder

Cylindrically grind the blade reel cylinder when it is worn away and has become conical. (Ask the dealer you purchased the machine from for cylindrical grinding.)

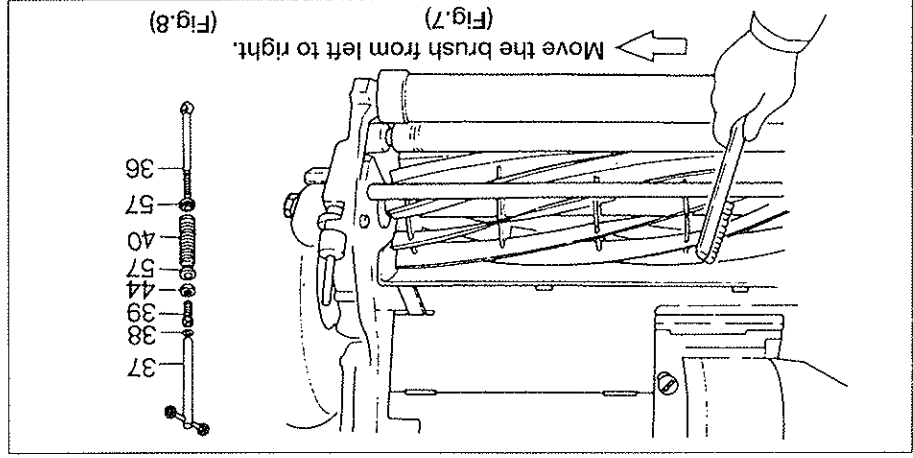

9-5. [IMPORTANT] Installation of blade reel cylinder

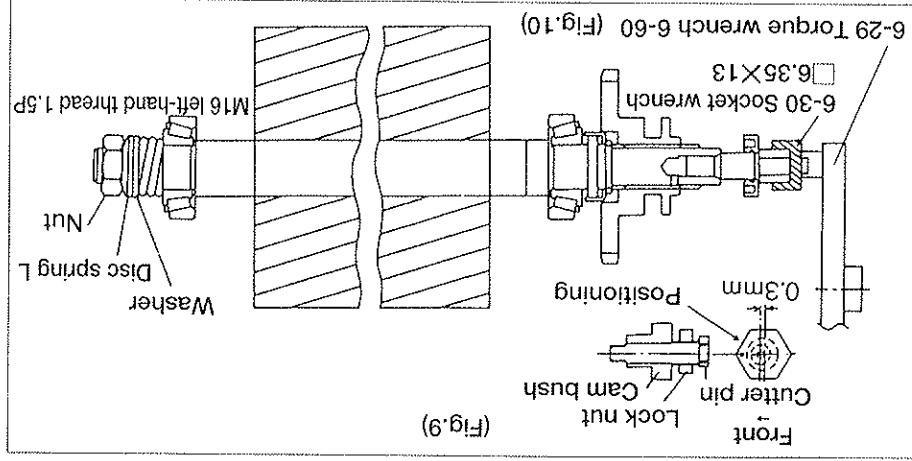

- (a) Replace the bearing and reel shaft seal on both sides of the blade reel cylinder. Use 30204RP6 that has the smallest error.
- (b) Sufficiently apply grease (EXCELITE EPN02) to the bearing and seal. (Apply grease while turning the roller. The grease will be sufficient for one season.)
- (c) Method to fasten nut after installing the blade reel cylinder

[IMPORTANT] Completely fasten the nut on the inside to firmly secure the bearing. The fastening torque is 360 kgf-cm. A certain preload will be applied by the spring pressure. The rotational torque of the blade reel cylinder should be 8-10 kgf-cm. If it is not, check the bearing and seal.

10. Long-term storage

- a. For the engine, refer to the engine operation manual.
- b. Cylindrically grind the blade reel cylinder every six months.
- c. Replace the bearing (30204RP6) and seal on both sides of the blade reel cylinder every season. (Replace them even if they have not been used for many hours.)
- d. Clean the machine, and apply grease or oil to respective sliding sections.

11. Precautions for engine operation



For the engine, refer to the engine operation manual.

- (1) Use gasoline for automobiles as the fuel of the engine.
- (2) Completely change engine oil when the machine has been used for five hours after the initial operation, because the machine is used under tough conditions with vibration and dust. Check the element in 15 hours, and change oil every 50 hours. The quantity of engine oil is 0.6 liter. Use SAE30.
- (3) Always cover the suction port of the air cleaner with a cleaner cover bag during operation. Be sure to clean the air cleaner element before using the machine, and replace the element with a new one every 200 hours.



- (4) Fire is strictly prohibited during fuel supply. Be careful of a lit cigarette. Supply fuel outdoors after the engine is stopped and cooled.
- (5) Do not start the engine in a building without a proper ventilator.

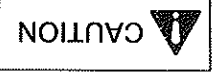

- (6) The muffler and the area around the exhaust port of the muffler will become hot. Do not bring gasoline, matches, dry grass, or other inflammables near hot portions.

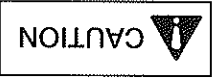

- (7) Inspection before operation
Check the joint of fuel pipe, etc. for looseness or damage. Check bolts and nuts in

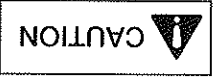

- (8) Wear appropriate clothes. An apron, towel on the belt, long string, etc. will cause you to be caught in rotating parts.
- (9) When the machine is to be stored for a long time exceeding 5 months, remove gasoline from the engine.
- (10) Engine maintenance schedule
To keep the engine in satisfactory status at all times, be sure to conduct maintenance and inspection according to the following table:

Operation hours	Every 5 hr	Every 8 hr	Every 50 hr
Inspection/supply of engine oil		○	
Engine oil change	First time		Second time forward
Cleaning of air cleaner	○		

For details, see the engine operation manual.

12. Special optional parts

(For blade reel cylinder change)

Special type
Lawn mowing impossible

12-1. Vertical detaching reel

Instead of a blade reel cylinder, a spiral detaching reel can be installed for detaching.

The working depth is 2 mm underground.

※ In the case of a green mower, use wheel gears (4-48/4-49/4-50) for teeing

ground mower to lower the operation speed. (Reference: Parts Catalog, pp.23 and

24.)

Thickness of vertical blade: 0.8 mm Diameter of vertical blade: φ 128 mm

12-2. Rotary brush for sweeper

Instead of a blade reel cylinder, a spiral rotary brush can be installed for detaching, and collection of fallen leaves.

Vertical detaching reel	Working width (cm)	Number of detaching blades	Working width (cm)	LM22 Series	LM26 Series
				484	574
Rotary brush	Working width (cm)	Dia. of brush (cm)		42	583
				36	493
				φ 135	φ 135

12-3. Special optional tools and reel rotational torque measuring instrument

Use of ⑨ and ⑩ in the blade reel cylinder installation diagram in Fig.10 permits measurement of the rotational torque (8-10 kgf-cm) of the blade reel cylinder.

Optional tools

- ① Spanner: 8 × 10 K4810080102
- ② Spanner: 13 × 17 K4810130172
- ③ Spanner: 19 × 22 K4810190222
- ④ Spanner: 24 × 27 K4810240272
- ⑤ Pliers K4830000012
- ⑥ +/- screwdrivers K4820000010
- ⑦ Reel lapping handle K6125000052
- ⑧ — screwdriver N-through K4820000020
- ⑨ Torque wrench: 6-60 K4802000370
- ⑩ Socket: 6.35 × 13 socket wrench K4802000352
- ⑪ Socket: 6.35 × 27 socket wrench K4802000362

For measurement of reel rotational torque

12-4. Common Parts in Parts List

○ : Common to LM22GE

△ : Common to LM55GD

※ : Parts of 26 only

BRP LAWN MOWER

GREEN MOWER
LM22GF
LM26GF
TEEING GROUND MOWER
LM26TF

PARTS CATALOG

☆ Ordering parts

All parts in this parts catalog are controlled by computer. However for prevention of delivery of wrong parts, advise us of the catalog No., code No., and part name.

(Example)	Catalog No.	Code No.	Part Name	Qty
	1-1	K691100050	Engine clutch	1

1. Engine clutch / stand

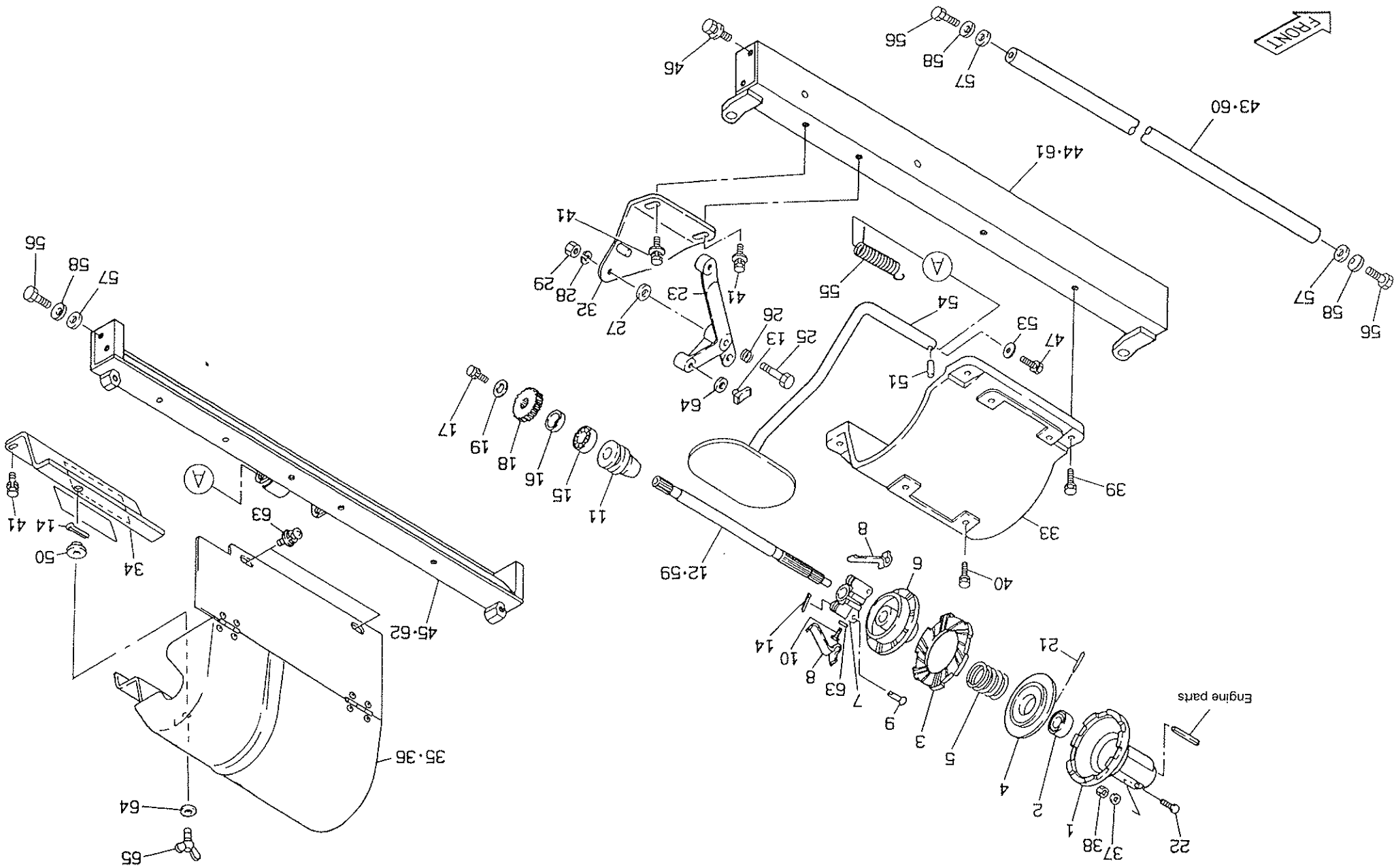

LM22GF、26GF
LM26TF

LM22GF、26GF
LM26TF

1. Engine clutch stand

Catalog No.	Code No.	Part Name	Qty /Unit	Common Part	Retail Price
1-36	K 91 00 00 1 2 0	Clutch cover ASSY 325	1	○	
1-37	K 50 00 06 00 2	6 washer	1	○	
1-38	K 01 43 06 00 2	6 nut with disc spring	1	○	
1-39	K 00 07 08 03 2	8 bolt 30SW	4	○	
1-40	K 00 07 08 04 2	8 bolt 40SW	4	○	
1-41	K 00 07 08 01 5 2	8 bolt 15SW	2	○	
1-42	K 6 2 2 5 0 0 0 3 3	8.5 pipe 17581	1	○	
1-44	LM 2 2 GF-0 7 1 3 Z R	Front frame stay	1		
1-45	LM 2 2 GF-0 7 1 4 Z R	Rear frame stay	1		
1-46	K 00 80 10 04 0 3	10 bolt 40HW	6	○	
1-47	K 00 06 06 01 5 3	6 bolt 15S	1	○	
1-48					
1-49					
1-50	K 40 31 00 02 5 0	10 staged rubber 224.5	1	△	
1-51	K 03 20 04 02 2 1	4 spring pin 22	1	○	
1-52					
1-53	K 50 12 30 62 5 2	2.3SPCC washer 625	1	○	
1-54	K 78 99 00 04 1 D	Stand	1	○	
1-55	K 10 90 00 00 2 9	Stand spring R	1	○	
1-56	K 00 71 00 05 9 2	M10 knock bolt 40	4	○	
1-57	K 50 02 10 00 0 3	10 washer 22	4	○	
1-58	K 02 13 10 00 0 2	10 disc spring washer 1H	5	○	
*1-59	LM 2 6 GE-0 3 1 2 D 2	Clutch shaft	1		
*1-60	LM 2 6 GE-0 5 1 0 Z 2	Stay pipe	1		
*1-61	LM 2 6 GF-0 7 1 3 A R	Front frame stay	1		
*1-62	LM 2 6 GF-0 7 1 4 Z R	Rear frame stay	1		
1-63	K 00 44 06 01 5 2	6 + round head screw 15SW	2	○	
1-64	K 50 00 08 00 0 2	8 washer	1	○	
1-65	K 00 71 00 08 8 2	8 wing bolt 15 with hole	1	△	
1-66					
1-67					
1-68					
1-69					
1-70					

○: Parts common to LM22GE △: Parts common to LM55GD ※: Parts of LM26GF

Catalog No.	Code No.	Part Name	Qty /Unit	Common Part	Retail Price
1-1	K 69 11 00 00 5 0	Engine clutch	1	○	
1-2	K 06 16 06 20 2 0	Bearing 62022NS3C	1	○	
1-3	K 18 10 00 00 3 0	Clutch disc	1	○	
1-4	K 69 11 00 00 1 2	Disc receiver	1	○	
1-5	K 10 00 00 01 6 0	3.5 compression spring 3415	1	○	
1-6	K 69 11 00 00 2 2	Clutch plate	1	○	
1-7	K 63 10 00 00 1 2	Lever mounting base	1	○	
1-8	K 10 90 00 00 1 0	Clutch spring	2	○	
1-9	K 60 40 06 02 8 2	6 round head pin 28	2	○	
1-10	K 00 13 06 02 5 1	6 heat treated bolt 25	1	○	
1-11	K 63 11 00 00 1 2	Clutch	1	○	
1-12	LM 2 2 GE-0 3 1 2 D 2	Clutch shaft	1	○	
1-13	K 63 10 00 00 2 2	Clutch mover	1	○	
1-14	K 03 00 02 01 6 2	2 cotter pin 16	2	○	
1-15	K 06 16 06 20 3 0	Bearing 62032NS3C	1	○	
1-16	LM 2 2 GE-0 3 1 7 B 0	16-tooth gear collar	1	○	
1-17	K 00 06 08 02 0 2	8 bolt 20S	1	○	
1-18	K 61 80 00 00 1 0	1-shaft 16-tooth gear	1	○	
1-19	K 50 12 30 82 6 2	2.3SPCC washer 826	1	○	
1-20					
1-21	K 03 10 05 04 0 2	5 taper pin 40	1	○	
1-22	K 00 00 06 03 0 2	6 bolt 30	1	○	
1-23	K 69 11 00 00 3 2	Clutch L-shaped lever	1	○	
1-24					
1-25	K 00 03 10 05 0 2	10 bolt 50	1	○	
1-26	K 10 00 00 02 0 8	2 compression spring 1514	1	○	
1-27	K 50 11 01 02 0 2	1SPCC washer 1020	1	○	
1-28	K 02 13 10 00 0 2	10 disc spring washer 1H	1	○	
1-29	K 01 00 01 00 0 2	10 nut	1	○	
1-30					
1-31					
1-32	K 73 09 00 02 R	L-shaped lever mounting bracket	1	○	
1-33	K 68 10 00 00 6 0	Engine base M	1	○	
1-34	K 80 05 00 03 0	Clutch cover mounting Ass'y	1	△	
1-35	K 91 00 00 00 6 0	Clutch cover ASSY 265	1	△	

2. Drum wheel

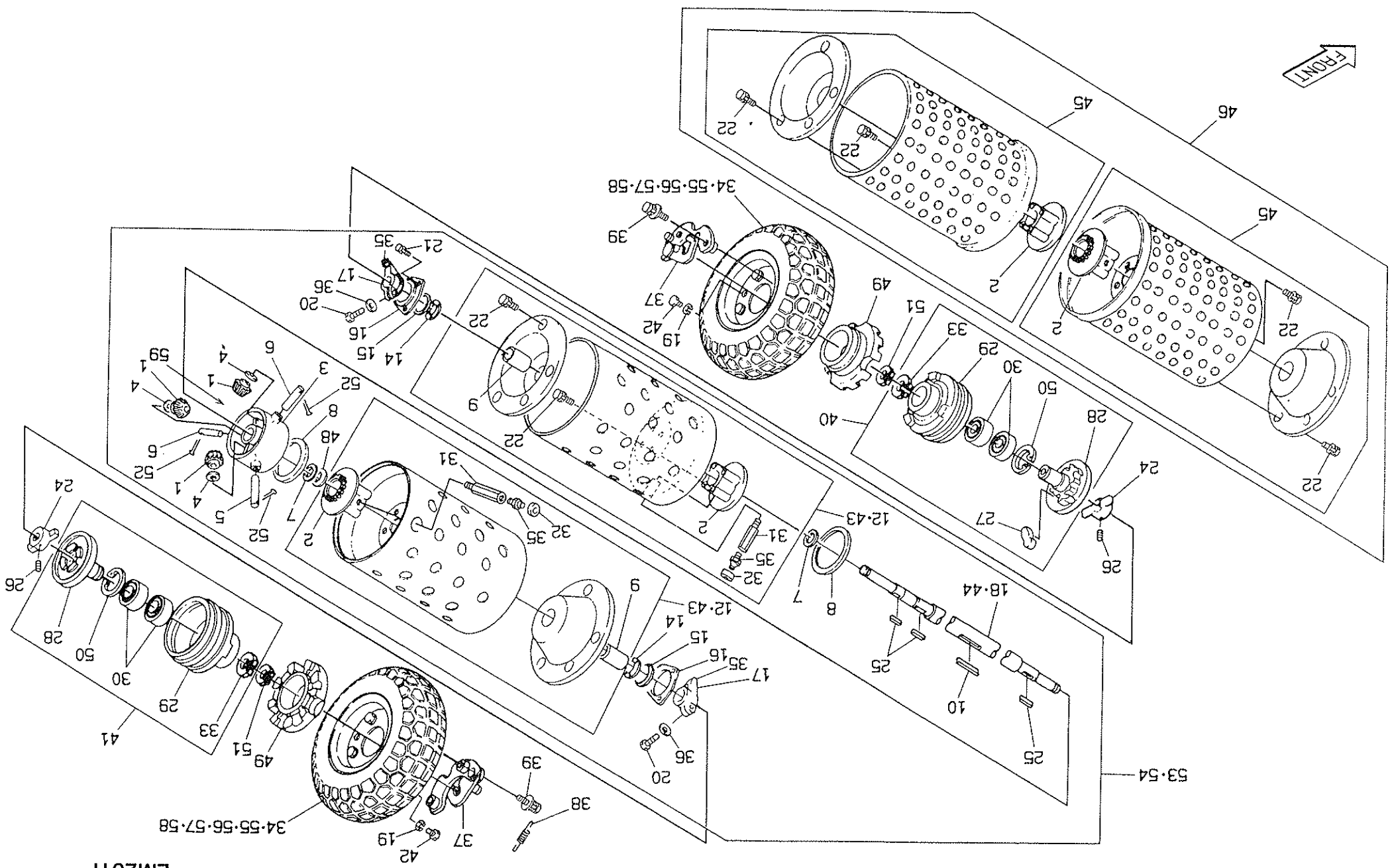

LM22GF, 26GF
LM26TF

Catalog No.	Code No.	Part Name	Qty /Unit	Common Part	Retail Price
2-1	K 6 1 9 1 0 0 0 2 0	Differential pinion	3	○	
2-2	K 6 1 9 1 0 0 0 3 2	21-tooth differential gear	2	○	
2-3	K 6 8 1 0 0 0 0 2 0	Differential housing	1	○	
2-4	K 5 0 5 1 0 1 0 2 2 0	1C5191P washer 1022	3	○	
2-5	K 6 1 5 6 0 0 0 2 0	Differential pinion shaft 1	1	○	
2-6	K 6 1 4 2 0 0 0 1 0	Differential pinion shaft 2	2	○	
2-7	K 5 0 5 1 0 2 5 3 7 0	1C5191P washer 25.437	2	○	
2-8	K 0 8 3 0 0 0 0 3 0	Differential dust seal	2	○	
2-9	K 6 0 0 0 0 0 0 3 0	25.4 bush 30.142	4	○	
2-10	K 0 5 0 0 4 0 4 3 5 0	4 both-end round key 435.5	1	○	
2-11	L M 2 2 G E - 0 2 1 0 A R	LM22G drum	2		
2-13	K 5 0 9 0 0 0 0 1 9 0	Drum washer	2	○	
2-14	K 4 0 0 7 4 1 0 5 0 0	6.3 felt 41.550	2	○	
2-16	K 5 3 7 0 0 0 0 0 7 2	Drum bearing cover	2	○	
2-17	K 6 5 1 0 0 0 0 1 2	Drum bracing	2	○	
2-18	L M 2 2 G E - 0 2 3 3 A 2	Axle	1	○	
2-19	K 0 2 0 0 8 0 0 0 2	8S washer	6	○	
2-20	K 0 0 1 0 0 8 0 2 5 2	8 heat treated bolt 25	2	○	
2-21	K 0 0 0 7 0 6 0 1 2 2	6 bolt 12SW	6	○	
2-22	K 0 0 0 7 0 8 0 2 0 2	8 bolt 20SW	18	○	
2-23	K 6 5 1 0 0 0 0 0 1 2	Clutch for axle	2	○	
2-24	K 5 0 0 5 0 5 2 0 0	5 both-end round key 520	3	○	
2-26	K 0 0 2 3 0 8 0 0 6 1	8 hollow set 6	2	○	
2-27	K 6 9 0 9 0 0 0 0 5 6	Clutch finger	6	○	
2-28	K 6 8 1 0 0 0 0 0 4 0	Ratchet gauge	2	○	
2-29	K 6 9 1 6 0 0 0 0 1 2	56 wheel hub	2	○	
2-30	K 0 6 1 3 0 6 0 0 5 0	Bearing 60052RDC3	4	○	
2-31	K 6 0 8 1 0 0 0 0 1 2	Oiling pipe	2	○	
2-32	K 4 0 3 1 0 0 0 1 2 0	Nipple cock	2	○	
2-33	K 0 4 0 1 0 2 5 0 0 1	Stop ring S25	2	○	
2-34	K 2 0 2 0 0 0 0 0 5 0	Tire 4.10/3.50 - 6 Ass'y	2	○	
2-35	K 1 4 4 0 0 0 0 0 1 2	Grease nipple	4	○	

2. Drum wheel

Catalog No.	Code No.	Part Name	Qty /Unit	Common Part	Retail Price
2-36	K 0 2 1 5 0 8 0 0 0 1	8 disc spring washer 2H	2	○	
2-37	K 7 1 4 8 0 0 0 6 2	Axle stopping bracket	2	△	
2-38	K 1 0 3 0 0 0 0 6 8	1.5U hook spring 8.535.5	2	○	
2-39	K 0 0 0 6 0 8 0 3 0 2	8 bolt 30S	4	○	
2-40	K 8 0 0 5 0 0 0 0 1 0	Left axle clutch	1	○	
2-41	K 8 0 0 5 0 0 0 0 2 0	Right axle clutch	1	○	
2-42	K 0 0 0 0 8 0 1 2 2	8 bolt 12	6	○	
2-43	K 8 0 2 0 0 0 0 0 1 R	Drum wheel Ass'y	2	○	
2-44	L M 2 2 G E - 0 2 3 3 A 2	Axle	1		
2-45	L M 2 2 G E - 0 2 1 0 A 0	LM22G drum	2		
2-46	L M 2 2 G E - 0 2 0 1 A 0	Drum Ass'y	1		
2-47	K 5 0 1 0 6 2 5 3 7 2	0.6SPCC washer 25.437	1	○	
2-48	K 2 1 6 0 0 0 0 0 1 2	Wheel mounting seat	2	○	
2-49	K 0 4 0 2 0 4 7 0 0 1	Stop ring R47	2	○	
2-51	K 0 4 0 1 0 1 7 0 0 1	Stop ring S17	2	○	
2-52	K 0 3 0 2 0 2 5 2 5 0	2.5 stainless steel cotter pin 25	3	○	
2-53	L M 2 2 G E - 0 2 0 1 A 0	Drum Ass'y	1		
2-54	L M 2 2 G E - 0 2 0 1 A 0	Drum Ass'y	1		
2-55	K 2 0 2 1 0 0 0 0 3 0	Tire 4.10/3.50-6	2	○	
2-56	K 2 0 9 0 0 0 0 5 0 L	Wheel 3SP-6	2	○	
2-57	K 2 0 9 0 0 0 0 5 1 L	Wheel 3SP-6 with valve hole	2	○	
2-58	K 2 0 9 1 0 0 0 2 2 0	Tube 4.10/3.50-6	2	○	
2-59	K 2 9 3 1 0 0 0 0 0 0	EXCELITE EP No.2	150g		

○: Parts common to LM22GE △: Parts common to LM56GD ※: Parts of LM26GF ☆: Parts of LM26TF

LM22GF、26GF
LM26TF

3. Blade reel cylinder/front roller/bottom blade

LM22GF、26GF
LM26TF

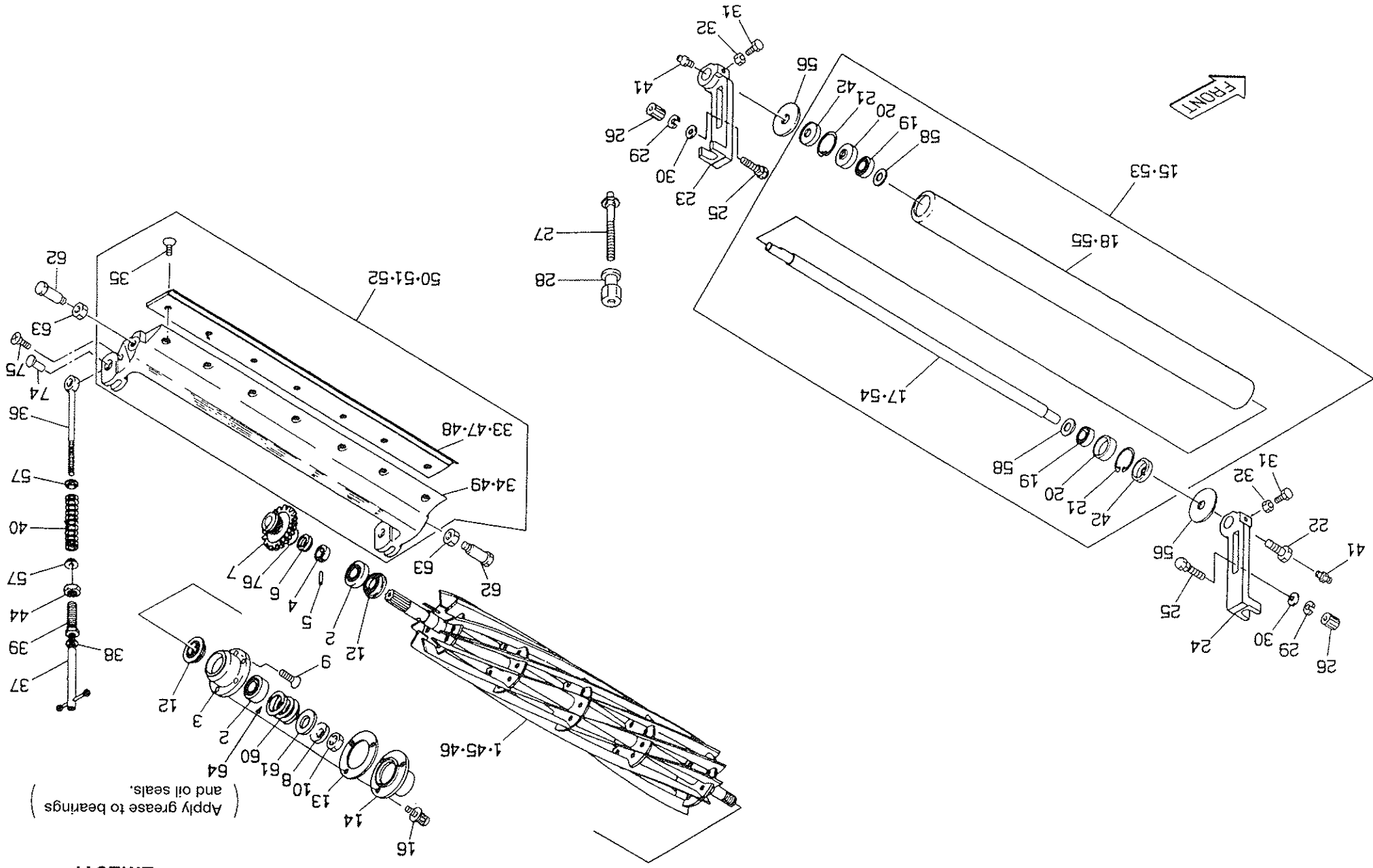

Catalog No.	Code No.	Part Name	Qty /Unit	Common Part	Retail Price
3-1	K 2 8 0 2 2 0 0 9 F R	Blade reel cylinder 557-9	1	○	
3-2	K 0 6 3 1 3 0 2 0 4 0	Tapered roller 30204JRP6	2	○	
3-3	K 6 9 0 3 0 0 0 0 6 2	Reel housing	1	○	
3-4	K 6 2 1 3 0 0 0 0 4 0	Left bearing collar	1	○	
3-5	K 0 3 1 1 0 4 5 2 5 0	4.5 needle roller 25.8	1	▽	
3-6	K 5 3 0 0 0 0 0 2 8 2	Pinning cover	1	○	
3-7	L M 2 2 G F - 0 1 0 7 Z 0	LM22GF-0107Z0	1	○	
3-8	K 0 2 1 0 1 6 0 0 0 1	16 disc spring L	1	▽	
3-9	K 0 0 4 1 0 8 0 2 5 2	8 + countersunk head screw 25	3	○	
3-10	K 0 1 8 5 1 6 0 0 0 2	16 left-hand threaded nut 3P1.5	1	▽	
3-11	K 0 8 3 0 0 0 0 0 2 0	Oil seal 254210	2	○	
3-12	K 4 0 1 1 0 0 0 0 7 0	Reel packing	1	○	
3-13	K 6 9 0 2 0 0 0 0 1 2	Reel shaft cover	1	○	
3-14	K 8 0 2 1 0 0 0 0 1 0	Front roller Assy 577	1	○	
3-15	K 0 0 6 0 8 0 2 0 2	8 bolt 20S	3	○	
3-16	K 6 1 3 1 0 0 0 1 2 2	Front roller shaft 596	1	○	
3-17	K 7 4 0 0 0 0 0 1 2 D	60 roller 577	1	○	
3-18	K 0 6 1 3 0 6 2 0 2 0	Bearing 62022NSEC3	2	○	
3-19	K 0 8 6 1 0 0 0 0 3 0	Oil seal 6202	2	○	
3-20	K 0 4 0 2 0 4 2 0 0 1	Stop ring R42	2	○	
3-21	K 6 0 8 3 0 0 0 0 4 2	15 extension pin 19	1	○	
3-22	K 6 8 0 4 0 0 0 0 2 0	Left roller bracket	1	○	
3-23	K 6 8 0 4 0 0 0 0 2 0	Right roller bracket	1	○	
3-24	K 6 8 0 4 0 0 0 0 1 0	8 square-base round-head bolt 35	2	○	
3-25	K 0 2 5 0 8 0 3 5 2	8 tall nut 20	2	○	
3-26	K 0 1 4 9 0 8 3 2 0 2	8 disc spring washer 1H	2	○	
3-27	K 7 9 0 0 0 0 0 0 5 0	Roller adjusting screw	2	○	
3-28	K 6 0 8 4 0 0 0 0 6 3	Roller adjuster	2	○	
3-29	K 0 2 1 3 0 8 0 0 0 1	2SPCC washer 818	2	○	
3-30	K 5 0 1 2 0 0 8 1 8 2	6 nut	2	○	
3-31	K 0 0 0 0 0 6 0 2 0 2	6 bolt 20	2	○	
3-32	K 0 1 0 0 6 0 0 0 2	6 nut	2	○	
3-33	K 2 5 1 1 0 0 0 1 5 0	22G bottom blade No.1	1	▽	
3-34	L M 2 2 G F - 0 5 0 8 Z R	Bottom blade base	1	○	
3-35	K 0 0 7 1 0 0 0 2 2	6 heat treated countersunk head screw 12	7	○	

3. Blade reel cylinder/front roller/bed knife

Catalog No.	Code No.	Part Name	Qty /Unit	Common Part	Retail Price
3-36	K 6 5 1 1 0 0 0 0 6 2	Cutter adjusting bolt 20S	2	▽	
3-37	K 1 3 3 0 0 0 0 0 4 0	Cutter adjuster Assy	2	○	
3-38	K 5 0 1 1 0 1 0 1 6 2	1SPCC washer 1016	2	○	
3-39	K 6 0 8 1 0 0 0 0 3 2	Threaded pipe	2	○	
3-40	K 1 0 0 0 0 0 0 2 8 8	5 compression spring 25116	2	○	
3-41	K 1 4 4 0 0 0 0 0 1 2	Grease nipple	2	○	
3-42	K 0 8 6 1 0 0 0 0 2 0	Oil seal TA1542.38	2	○	
3-43					
3-44	K 0 1 6 0 0 0 0 1 2 2	Cutter adjusting lock nut	2	○	
3-45	K 2 8 0 2 6 0 0 9 F R	Blade reel cylinder 577-9	1	○	
3-46	K 2 8 0 2 6 0 0 7 F R	Blade reel cylinder 577-7	1		
3-47	K 2 5 1 0 0 0 0 1 4 0	26G bottom blade No.1	1		
3-48	K 2 5 1 0 0 0 0 1 4 0	5 bottom blade 62.5-648.4	1		
3-49	L M 2 2 G F - 0 5 0 8 Z R	Bottom blade base	1		
3-50	L M 2 2 G F - 0 5 0 2 Z 0	Bottom blade COMP	1		
3-51	L M 2 2 G F - 0 5 0 2 Z 0	Bottom blade COMP	1		
3-52	L M 2 6 T F - 0 5 0 2 Z 0	Bottom blade COMP	1		
3-53	K 8 0 2 1 0 0 0 0 2 0	Front roller Assy 666	1		
3-54	K 6 1 3 1 0 0 0 1 3 2	Front roller shaft 685	1		
3-55	K 7 4 0 0 0 0 0 0 6 D	60 roller 666	1		
3-56	K 5 0 5 1 0 1 5 4 7 0	1C5191F washer 1547	2	○	
3-57	K 6 2 0 6 0 0 0 0 5 2	Spring receiver	4	○	
3-58	K 5 0 5 1 0 1 5 2 8 0	1C5191F washer 1528	2	○	
3-59	K 1 0 0 0 0 0 0 7 4 0	3.2 compression spring 26.922	1	▽	
3-61	K 5 0 1 2 0 1 6 2 8 2	2SPCC washer 1628	1	▽	
3-62	K 6 0 8 2 0 0 0 0 1 0	Cutter pin R	2	○	
3-63	K 0 1 6 0 0 0 0 1 1 3	Lock nut	2	○	
3-64	K 2 9 3 1 0 0 0 0 0 0 0	EXCELITE EP No.2	40g		
3-74	K 6 0 3 0 1 0 0 2 3 2	10 flat head pin 23	2	▽	
3-75	K 0 0 4 1 0 6 0 1 2 2	6 + countersunk head screw 12	2		
3-76	K 0 8 8 8 0 0 1 8 0 0 0	O-ring P18	1		

○: Parts common to LM22GF △: Parts common to LM55GD ※: Parts of LM26GF ☆: Parts of LM26TF

LM22GF、26GF
LM26TF

4. Frame/transmission

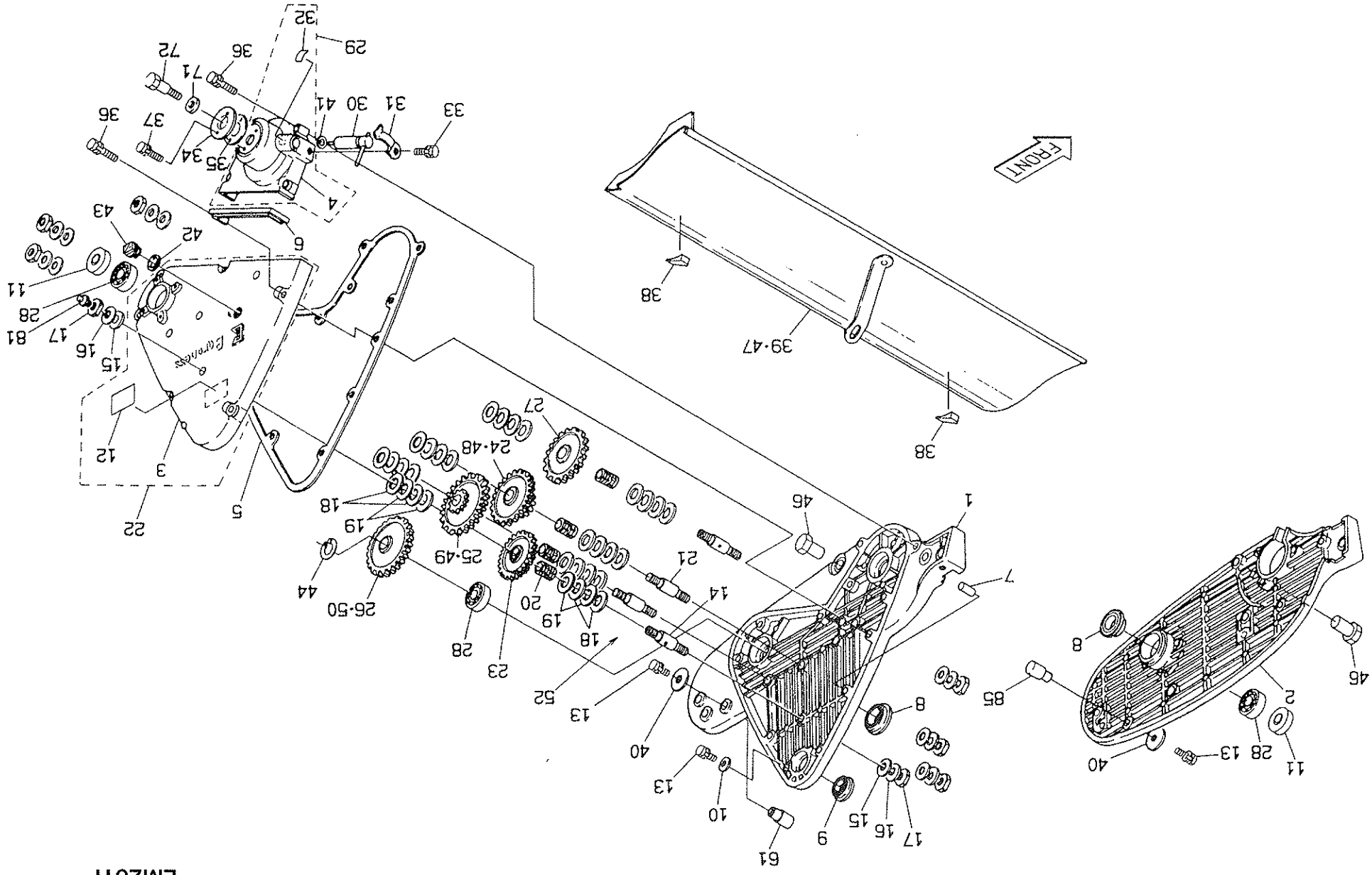

LM22GF、26GF
LM26TF

Catalog No.	Code No.	Part Name	Qty /Unit	Common Part	Retail Price
4-1	LM22GE-0601CR	Left frame	1	○	
4-2	LM22GE-0602BR	Right frame	1	○	
4-3	LM22GE-0603ZR	Frame cover	1	○	
4-4	LM22GE-0617ZR	Small frame cover	1	○	
4-5	LM22GE-0604Z0	Frame packing	1	○	
4-6	K4039000040	Joint packing	1	○	
4-7	K6051051200	5.1 heat treated pin 20	1	○	
4-8	K0830000020	Oil seal 254210	2	○△	
4-9	K0811930070	Oil seal MHS19307	1	○△	
4-10	K5011606163	1.6SPCC washer 616	1	○	
4-11	K0852042080	Oil seal PUN20428	2	○△	
4-12	K4209000370	10 hr greasing mark	1		
4-13	K0006060122	6 bolt 12S	3		
4-14	K6122000020	Intermediate shaft with tap	2	○	
4-15	K4015110200	1 fiber 10.220	8	○	
4-16	K5011010202	1SPCC washer 1020	8	○	
4-17	K0160000282	10 nut 3P10H1	8	○△	
4-18	K5051013280	1C5191P washer 1328	16	○△	
4-19	K5020813280	0.8NBS55 washer 1328	16	○△	
4-20	K0711317200	Needle KTW131720	4	○△	
4-21	K6122000030	Intermediate shaft	2	○	
4-22	LM22GF-0604Z0	Frame cover with mark	1		
4-23	K6183000010	2-shaft 42-tooth gear	1	○	
4-24	K6185000020	3-shaft 16-tooth 42-tooth gear	1	○	
4-25	K6185000030	5-shaft 15-tooth 45-tooth gear	1	○	
4-26	K6181000020	45-tooth axle gear	1	○	
4-27	K6183000020	4-shaft 42-tooth gear	1	○	
4-28	K0601062040	Bearing 6204C3	3	○△	
4-29	LM22GF-0617Z0	Frame cover with small mark	1		
4-30	K7321000092	Clutch handle	1	○△	
4-31	K1090000058	Clutch retainer spring	1	○△	
4-32	K4203000080	ON/OFF mark	1	○△	
4-33	K0027060122	6 + Hole upset bolt 12S	1	○△	
4-34	LM22GF-0109Z2	Cutter shaft seal collar	1		
4-35	LM22GF-0110Z0	Cutter shaft grease retaining rubber	1		

4. Frame/transmission

Catalog No.	Code No.	Part Name	Qty /Unit	Common Part	Retail Price
4-36	K0007060452	6 bolt 45SW	10		
4-37	K0006060202	6 bolt 20S	2	○	
4-38	K4039000030	Reel cover rubber	2	○	
4-39	LM22GE-0509AR	Cutter cover	1		
4-40	K5012306252	2.3SPCC washer 625	2	○	
4-41	K0880015000	O-ring P15	1	○△	
4-42	K4010217250	2 oil seat 17.525	1	○△	
4-43	K1400000010	Oil tap 18	1	○△	
4-44	K0401020001	Stop ring S20	1	○△	
4-45			2		
4-46	K6010000010	Cam bush	2	○△	
※4-47	LM26GE-0509AR	Cutter cover	1		
※4-48	LM5TB-0225Z0	3-shaft 15-tooth 42-tooth gear	1		
※4-49	LM5TB-0226Z0	5-shaft 14-tooth 46-tooth gear	1		
※4-50	LM5TB-0237A0	46-tooth gear	1		
4-51	K2929000000	DYNAMAX EP No.1	700g		
4-61	K6155000042	Handle mounting pin R	1	○	
4-71	K0821228070	Oil seal MHS12287	1	△	
4-72	K0071000878	10 special bolt 35	1	△	
4-81	K1440000012	Grease nipple	2		
4-85	LM22GE-0609Z2	Handle mounting pin ThreeBond 1104	1	○	15g
4-86	K2941000000				

○: Parts common to LM22GE △: Parts common to LM55GD ※: Parts of LM26GF ☆: Parts of LM26TF

LM22GF、26GF
LM26TF

5. Handle/engine

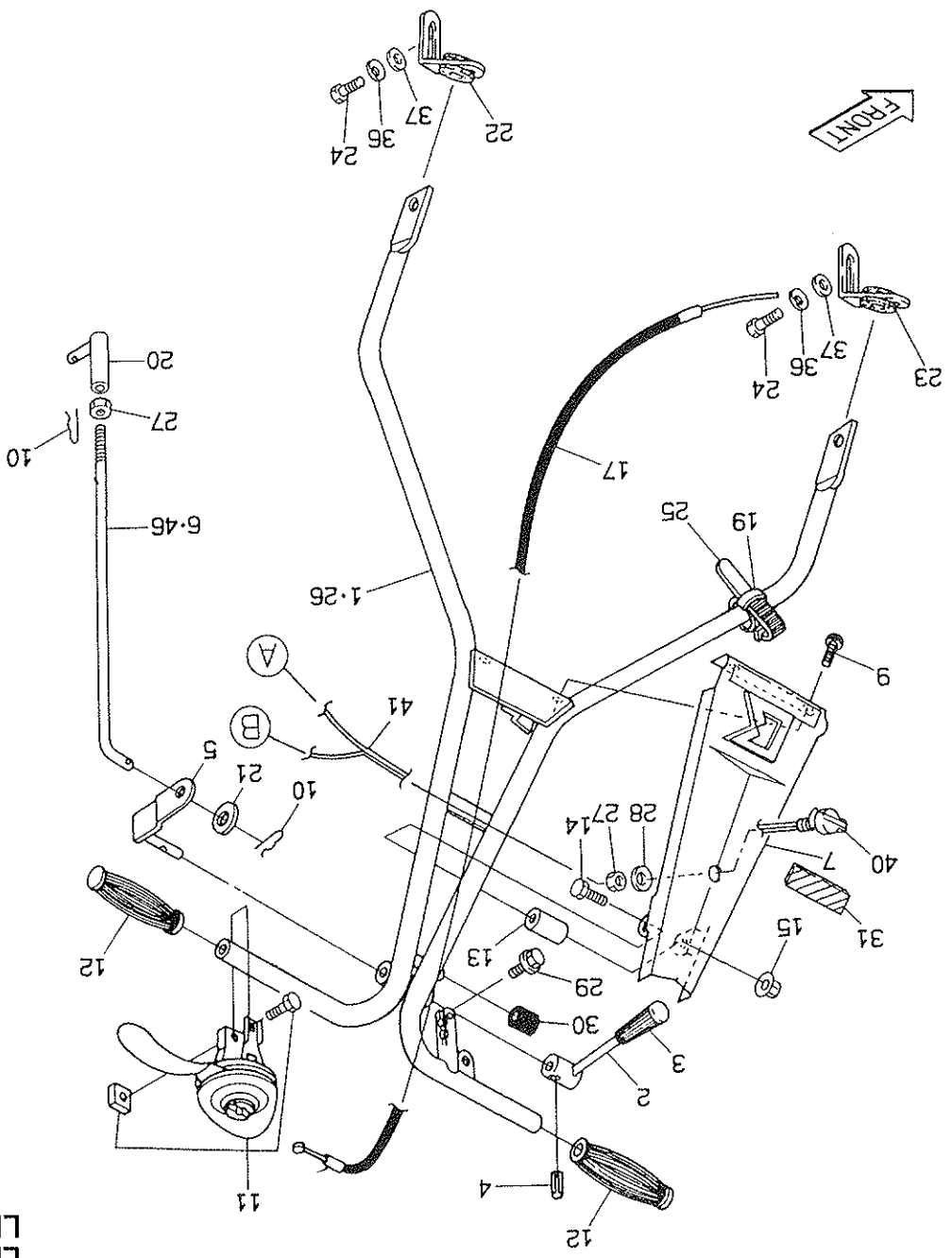
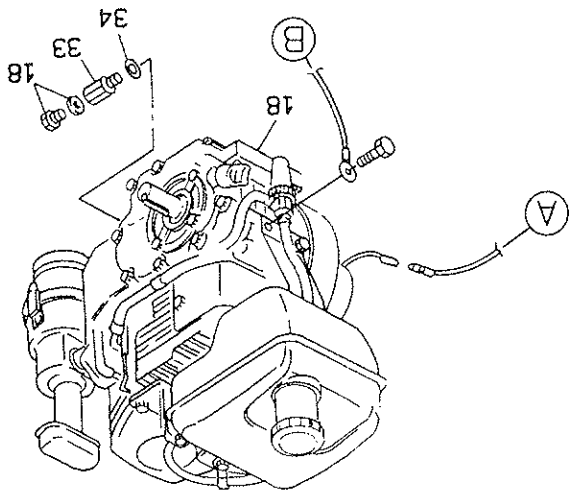

LM22GF, 26GF
LM26TF

○: Parts common to LM22GE △: Parts common to LM55GD ※: Parts of LM26GF

Catalog No.	Code No.	Part Name	Qty /Unit	Common Part	Retail Price
5-36	K 0 2 1 3 1 0 0 0 1	10 disc spring washer 117	2	○ △	
5-37	K 5 0 1 2 3 1 0 2 5 2	2.3SPCC washer 1025	2	○ △	
5-38					
5-39					
5-40	K 3 6 6 2 0 0 0 5 0	Engine switch FA56361-A	1	△	
5-41	K 3 6 2 0 0 0 5 5 0	Engine switch cord 8A	1	△	
5-42					
5-43					
5-44					
5-45	K 2 9 5 4 0 0 0 0 0	ThreeBond 1741	5g	△	
※5-46	K 7 3 0 1 0 0 0 0 6 3	Clutch rod	1		

Catalog No.	Code No.	Part Name	Qty /Unit	Common Part	Retail Price
5-1	K 9 2 0 0 0 0 0 0 7 0	Handle 54	1	△	
5-2	K 8 0 6 0 0 0 0 0 1 0	Travelling clutch lever	1	○ △	
5-3	K 1 3 0 0 0 0 0 0 7 0	9 black grip 22	1	○ △	
5-4	K 0 3 2 0 0 5 0 2 0 1	5 spring pin 20	1	○ △	
5-5	K 7 3 2 1 0 0 0 0 3 3	Clutch lever shaft	1	○ △	
5-6	K 7 3 0 1 0 0 0 0 6 3	Clutch rod 995	1	△	
5-7	K 5 3 7 0 0 0 0 0 4 L	Handle cover	1	△	
5-8					
5-9	K 0 0 4 8 0 4 0 0 6 2	4 + Round head screw 6S	2	○ △	
5-10	K 0 3 4 0 8 0 0 0 0 3	8 snap pin	2	○ △	
5-11	K 1 2 0 3 5 2 1 0 0 0	Throttle lever E352100	1	○ △	
5-12	K 1 3 0 0 0 0 0 1 4 0	Black handle grip 21	2	○ △	
5-13	K 6 2 1 1 0 0 0 0 3 2	6.5SGP collar 10.516	1	○ △	
5-14	K 0 0 4 2 0 5 0 2 5 2	5 + Round head screw 25	1	○ △	
5-15	K 0 1 4 3 0 5 0 0 0 2	5 nut with disc spring	1	○ △	
5-16					
5-17	K 1 1 0 1 3 5 0 0 0	Throttle wire 1350	1	○ △	
5-18	K 9 2 7 0 0 0 0 0 2 0	ROBIN EY150DD190	1	○	
5-19	K 4 2 4 1 0 0 0 0 7 0	Urethane tube 7	1	○ △	
5-20	K 7 3 0 9 0 0 0 0 1 2	Rod adjuster	1	○ △	
5-21	K 5 0 0 0 8 0 0 0 3	8 washer	1	○ △	
5-22	LM 2 2 GE - 0 7 1 5 2 0	Left handle adjuster	1	○ △	
5-23	LM 2 2 GE - 0 7 1 6 2 0	Right handle adjuster	1	○ △	
5-24	K 0 0 1 0 1 0 0 2 5 1	10 heat treated bolt 25	2	○ △	
5-25	K 4 2 4 1 0 0 0 0 1 0	Nylon band 140	2	○ △	
※5-26	K 9 2 0 0 0 0 0 0 8 0	Handle 64	1	△	
5-27	K 0 1 0 2 0 8 0 0 0 2	8 nut 3	2	△	
5-28	K 0 2 1 0 0 8 0 0 0 2	8 disc spring L	1	△	
5-29	K 0 0 0 6 0 5 0 2 0 2	5 bolt 20S	1	○ △	
5-30	K 4 0 3 1 0 0 0 0 1 0 0	Stopper rubber	1	○ △	
5-31	K 4 0 3 3 0 0 0 0 7 0	Handle cover rubber cushion	1	○ △	
5-32					
5-33	K 0 0 7 1 0 0 0 9 0 2	Threaded pipe of waste oil	1	○ △	
5-34	⊕ 0 2 1 - 1 1 4 0 0 - 2 0	Gasket	1	○ △	
5-35					

5. Handle/engine

LM22GF、26GF
LM26TF

6. Accessory parts / tools

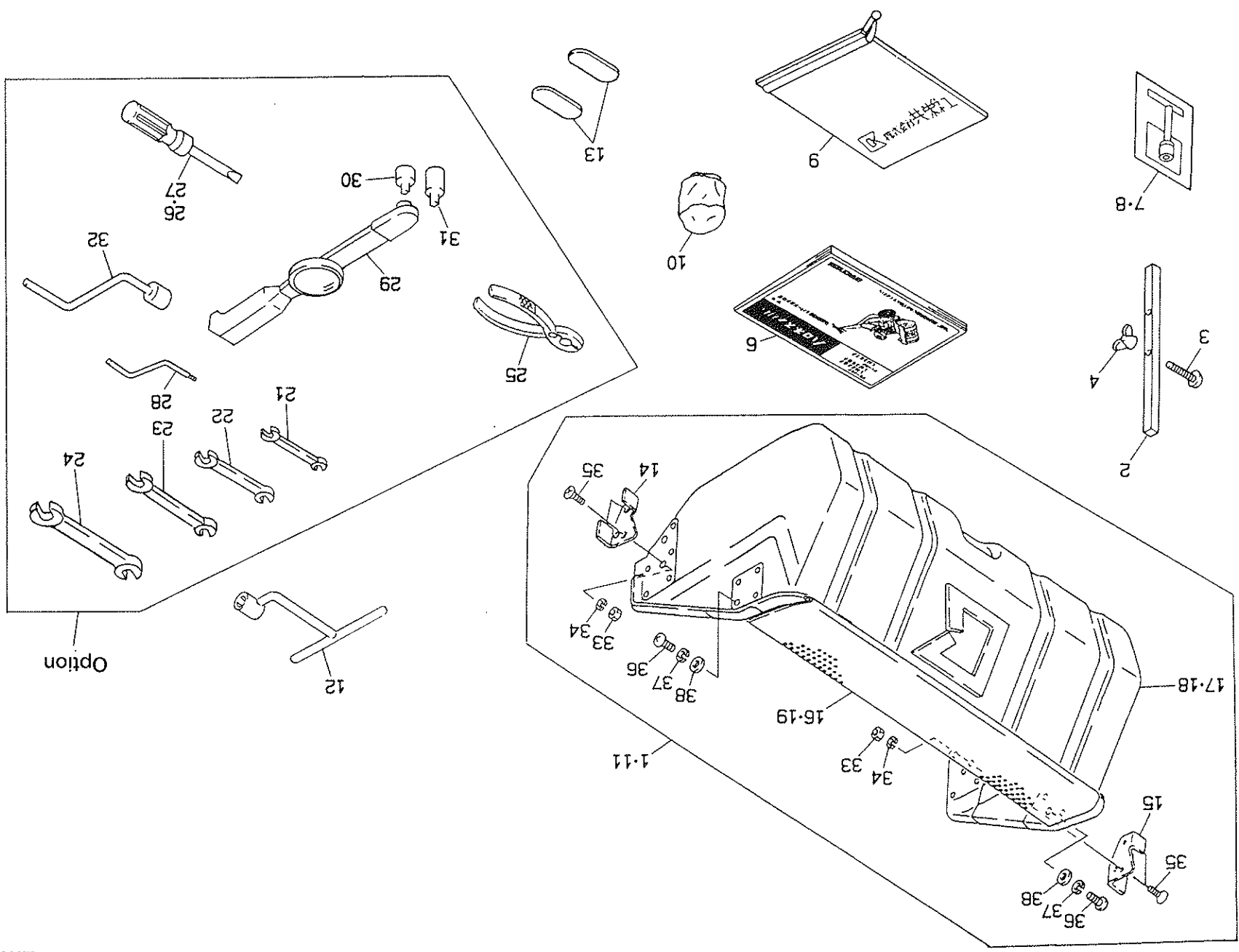

LM22GF、26GF
LM26TF

LM22GF、26GF
LM26TF

6. Accessory parts

Catalog No.	Code No.	Part Name	Qty /Unit	Common Part	Retail Price
6-36	K 0 0 4 2 0 8 0 2 0 2	8 + Round head screw 20	2	○ △	
6-37	K 0 2 0 0 0 8 0 0 0 2	8S washer	2	○ △	
6-38	K 5 0 0 0 0 8 0 0 0 2	8 washer	2	○ △	
6-39					

Catalog No.	Code No.	Part Name	Qty /Unit	Common Part	Retail Price
6-1	LM 2 2 G E - 0 8 0 0	Grass catcher	1	○	
6-2	K 6 9 0 0 0 0 0 5 2	Mowing height gauge	1	○	
6-3	K 0 4 6 0 6 0 5 0 2	6 + Tapping screw C-1 round head 50	1	○ △	
6-4	K 0 1 4 1 0 6 0 0 0 2	6 butterfly nut 3	1	○ △	
6-5					
6-6	LM 2 2 . 2 6 - 0 0 F - 0 1	Handling manual & parts catalog	1		
6-7	K 2 6 2 0 E Y 1 5 D - 1 0	EY15D tool	1	○	
6-8	K 2 6 2 0 E Y 1 5 D - 0 3	EY15D operation manual	1	○	
6-9	K 4 8 0 1 0 0 0 0 2 0	Tool bag	1	○ △	
6-10	K 4 1 1 0 0 0 0 0 6 0	Cleaner cover A	1	○ △	
*6-11	LM 2 6 G E - 0 8 0 0	Grass catcher	1	○	
6-12	K 4 8 0 2 0 0 0 0 9 2	Drum shaft adjustor	1	○	
6-13	K 4 8 0 2 0 0 0 1 2 0	0.5 thickness gauge	2	○ △	
6-14	K 5 2 7 6 0 0 0 1 3	Left latch	1	○	
6-15	K 5 2 7 6 0 0 0 2 3	Right latch	1	○	
6-16	K 7 1 6 3 0 0 0 1 0 D	Grass box cover 590	1	○	
6-17	K 7 9 0 0 0 0 0 0 3 0	Grass catcher 570COMP	1	○	
*6-18	K 7 9 0 0 0 0 0 0 2 0	Grass catcher 660COMP	1	○	
6-19	K 7 1 6 3 0 0 0 0 5 D	Grass box cover 675	1	○	
6-21	K 4 8 1 0 0 8 0 1 0 2	Spanner 8 x 10	1		
6-22	K 4 8 1 0 1 3 0 1 7 2	Spanner 13 x 17	2		
6-23	K 4 8 1 0 1 9 0 2 2 2	Spanner 19 x 22	1		
6-24	K 4 8 1 0 2 4 0 2 7 2	Spanner 24 x 27	1		
6-25	K 4 8 3 0 0 0 0 0 1 2	Pliers	1		
6-26	K 4 8 0 2 0 0 0 0 1 0	+/- screwdriver	1		
6-27	K 4 8 0 2 0 0 0 0 2 0	- screwdriver through 200	1		
6-28	K 6 1 2 5 0 0 0 0 5 2	Reel lapping handle	1		
6-29	K 4 8 0 2 0 0 0 3 7 0	Torque wrench 6-60	1		
6-30	K 4 8 0 2 0 0 0 3 5 2	□ 6.35 x 13 socket wrench	1		
6-31	K 4 8 0 2 0 0 0 3 6 2	□ 6.35 x 27 socket wrench	1		
6-32	K 4 8 0 2 0 0 0 3 8 2	Lapping handle	1		
6-33	K 0 1 0 0 0 6 0 0 0 2	6 nut	4	○ △	
6-34	K 0 2 0 0 0 6 0 0 0 2	6S washer	4	○ △	
6-35	K 0 0 4 1 0 6 0 2 0 2	6 + Countersunk head screw 20	4	○ △	

○: Parts common to LM22GE △: Parts common to LM55GD ※: Parts of LM26GF

7. Internal expanding brake parts

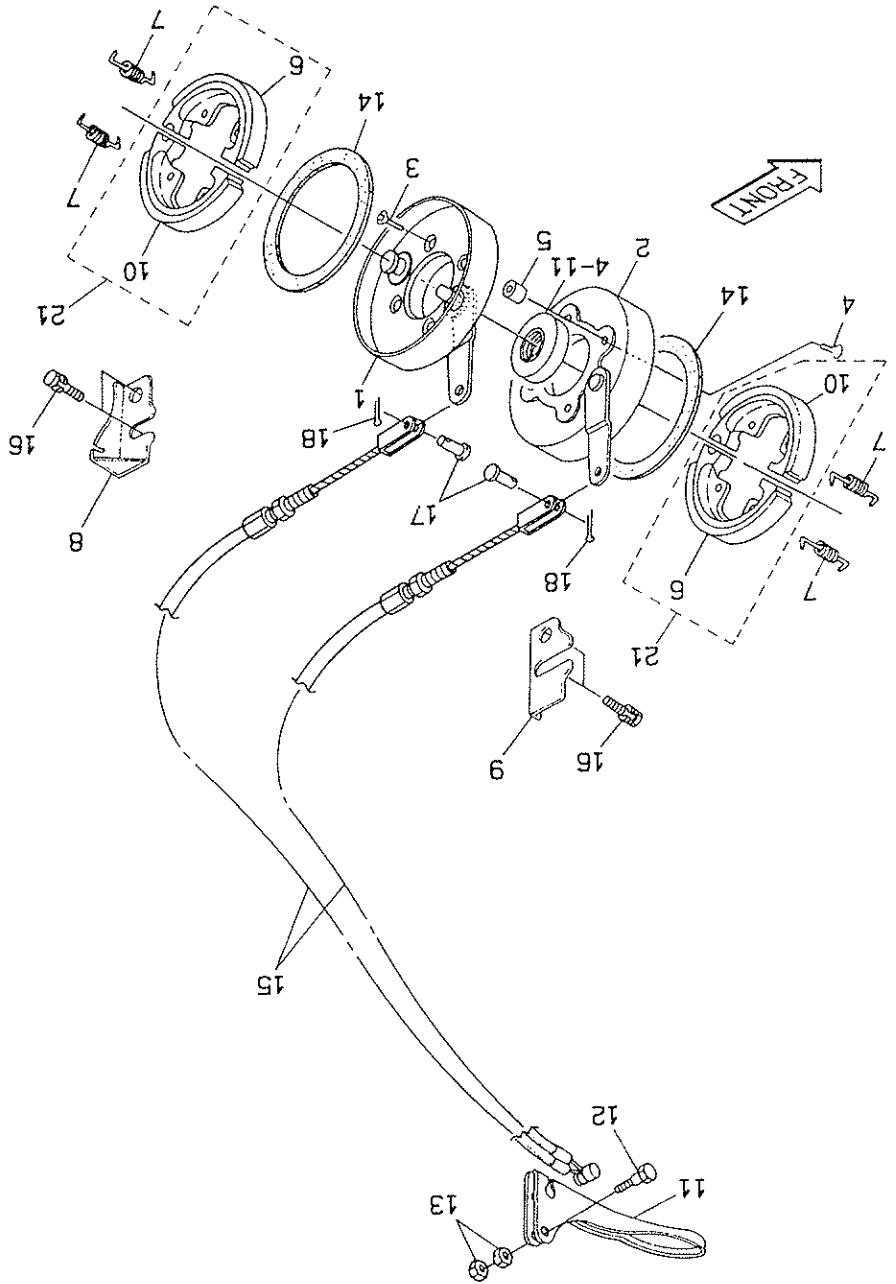

LM22GF、26GF
LM26TF

○: Parts common to LM22GE △: Parts common to LM55GD

Code No.	Part Name	Qty /Unit	Common Part	Retail Price
7-1	LM 22GE-1102Z2	1	○	
7-2	LM 22GE-1103Z2	1	○	
7-3	K 0041060202	4	○	
7-4	K 0041060252	4	○	
7-5	LM 22GE-1106Z2	4	○	
7-6	K 1725000010	2	○△	
7-7	K 1040000010	4	○△	
7-8	LM 22GE-1108A2	1	○	
7-9	LM 22GE-1109B2	1	○	
7-10	K 1725000020	2	○△	
7-11	K 1241132014	1	○△	
7-12	K 0071000213	1	○△	
7-13	K 0102060003	2	○△	
7-14	K 4009000010	2	○△	
7-15	K 1120140000	2	○△	
7-16	K 0007100402	4	○	
7-17	K 6030050122	2	○△	
7-18	K 0300020162	2	○△	
7-19				
7-20	K 2941000000	10g		
7-21	K 1725000040	2		

Code No.	Part Name	Qty /Unit	Common Part	Retail Price

7. Internal expanding brake parts

LM22GF、26GF
LM26TF

8. Detaching reel (Option)

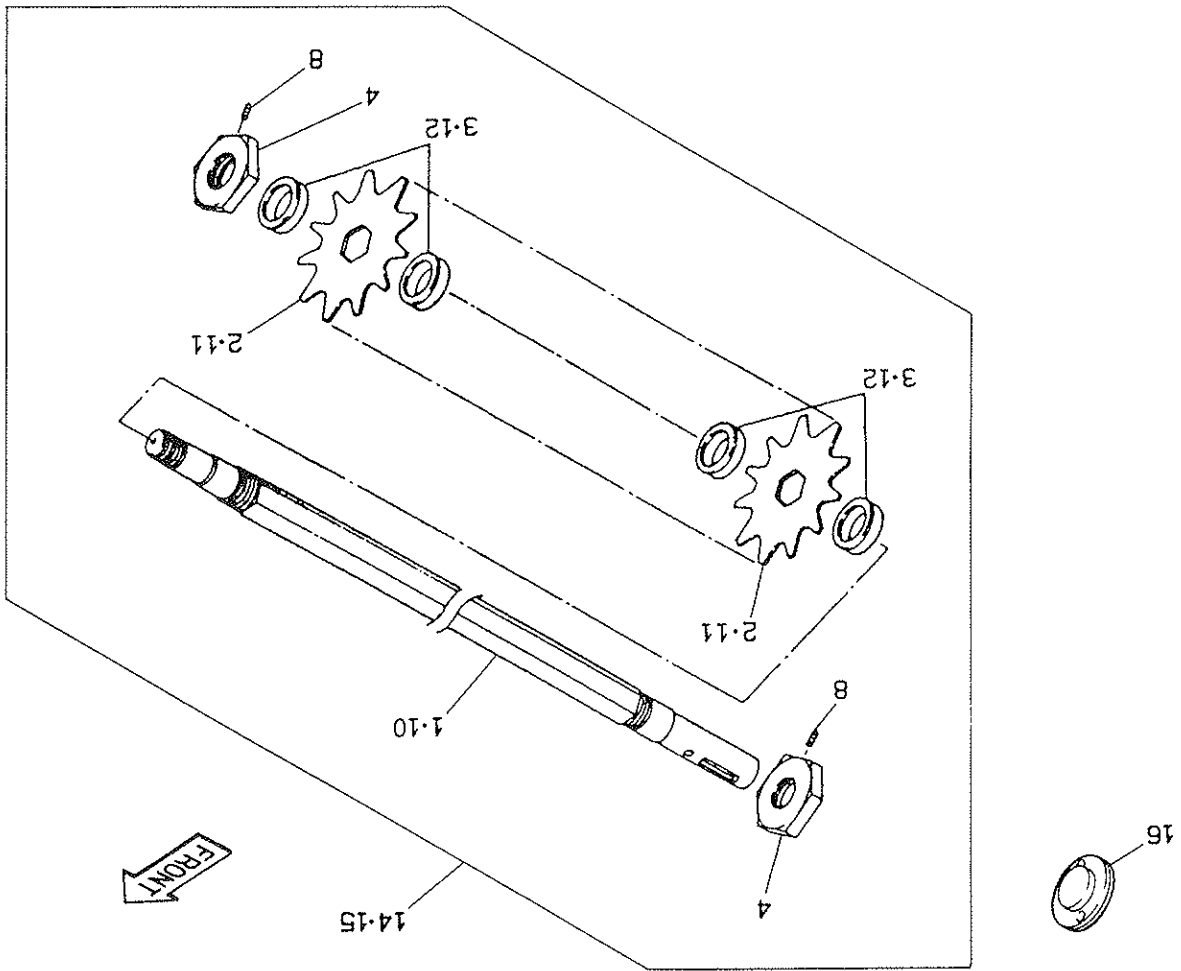

LM22GF、26GF
LM26TF

8. Dethatching reel (Option)

LM22GF、26GF
LM26TF

Catalog No.	Code No.	Part Name	Qty /Unit	Common Part	Retail Price
8-1	LM 2 2 G F - 1 7 0 2 Z 2	Vertical blades shaft	1		
8-2	K 2 5 7 0 0 0 0 2 9	Vertical blade 128	36		
8-3	K 6 2 1 2 0 0 1 1 7 2	31.7STKM collar 4213	37		
8-4	K 0 1 6 0 0 0 0 4 2 2	27 special nut P1.5-10	2		
8-5					
8-6					
8-7					
8-8	K 0 0 2 3 0 6 0 1 2 1	6 hollow set 12	2		
8-9					
※8-10	LM 2 6 G F - 1 7 0 2 Z 2	Vertical blades shaft	1		
※8-11	K 2 5 7 0 0 0 0 2 9	Vertical blade 128	43		
※8-12	K 6 2 1 2 0 0 1 1 7 3	31.7STKM collar 4213	44		
8-13					
8-14	LM 2 2 G F - 1 7 0 1 Z 0	Dethatching reel Ass'y	1		
※8-15	LM 2 6 G F - 1 7 0 1 Z 0	Dethatching reel Ass'y	1		
8-16	LM 2 2 G E - 0 1 0 9 Z 0	Cutter shaft grease retainer	1		

※: Parts of LM26GF

Catalog No.	Code No.	Part Name	Qty /Unit	Common Part	Retail Price

9. Sweeping brush (Option)

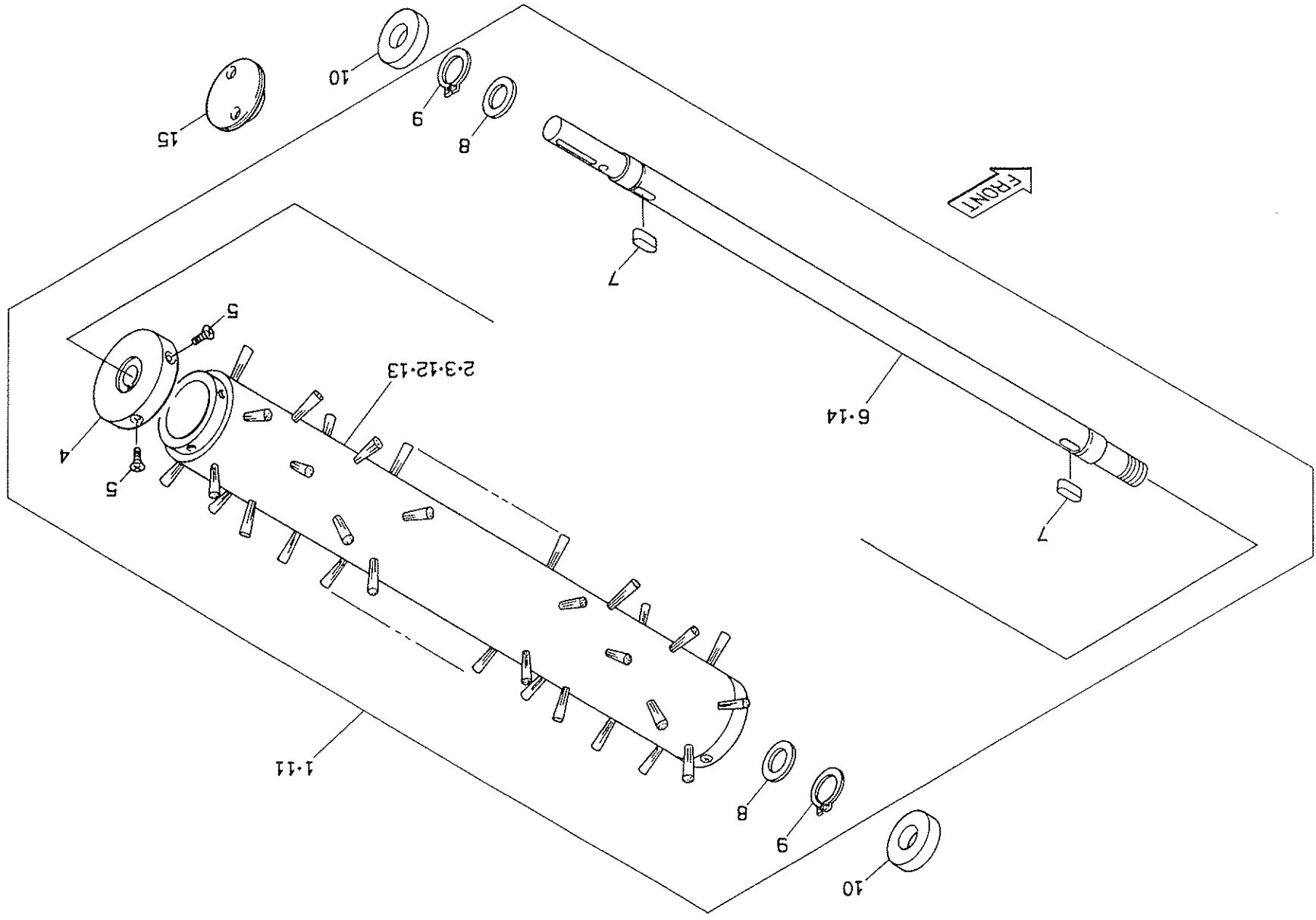

LM22GF、26GF
LM26TF

Catalog No.	Code No.	Part Name	Qty /Unit	Common Part	Retail Price

※: Parts of LM26GF

Catalog No.	Code No.	Part Name	Qty /Unit	Common Part	Retail Price
9-1	LM22GF-1601Z0	Brush shaft Ass'y	1		
9-2	K415000030	55 brush 135COMP	1		
9-3	K415000050	55 brush 135	1		
9-4	K620500082	Metal	1		
9-5	K0065380132	3.8 slotted countersunk head screw 13	8		
9-6	LM22GF-1602Z2	Brush shaft	1		
9-7	K0500505160	5 both-end round key 516	2		
9-8	K5051022300	1G5191F washer 2230	2		
9-9	K0401022001	Stop ring S22	2		
9-10	K0852242080	Oil seal PJN22428	2		
※9-11	LM26GF-1601Z0	Brush shaft Ass'y	1		
※9-12	K415000040	65 brush 135COMP	1		
9-13	K415000060	65 brush 135	1		
※9-14	LM26GF-1602Z2	Brush shaft	1		
9-15	LM22GE-0109Z0	Cutter shaft oil retainer	1		

9. Sweeping brush (Option)

LM22GF、26GF
LM26TF

 **KYOEISHA CO., LTD.** **BARONESSE**
Head Office 1-26, Miyuki-cho, Toyokawa,
Aichi-Pref. 442-8530 Japan. Turf Care Machinery
Tel : (0533) 84-1221
Fax: (0533) 84-1220