

GM2800B

Riding Quintuple Rotary Mower

Owner's operating manual

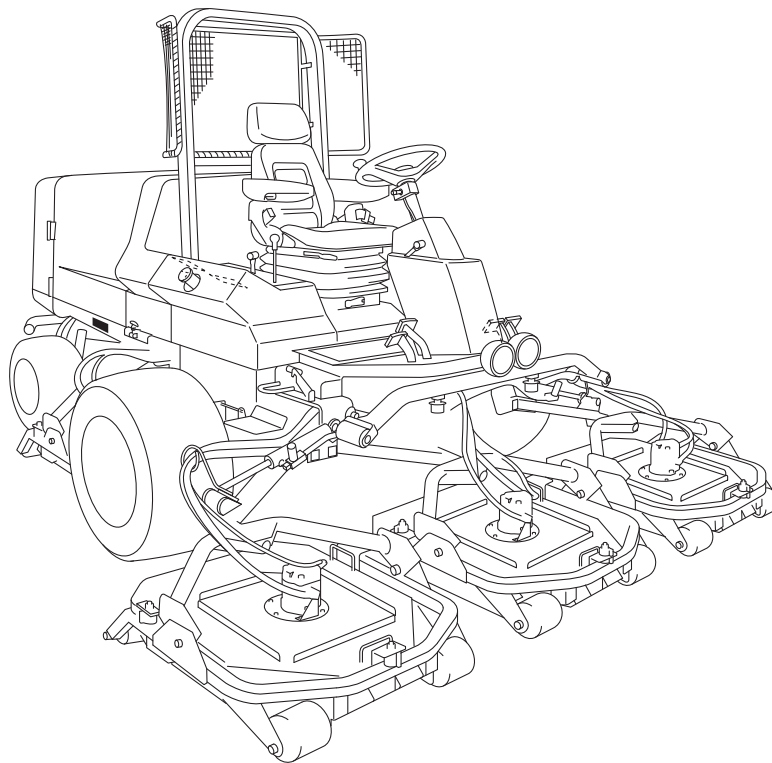

"Required reading" Read this manual and the owner's manual for the engine before using the machine.

BARONESS[®]
Quality on Demand

Serial No.10001 ~

Original Instructions Ver.1.0

Greeting

Thank you for purchasing the Baroness machine. This manual explains proper handling, adjustment, and inspection of your machine.

Prior to use, carefully read this manual to thoroughly understand the contents for safe and correct operation.

This machine has been shipped from the factory after comprehensive test runs and inspections.

However, the optimum performance of the machine depends on how you use and maintain it, including routine inspections, adjustments, and fuel supplies before and after the operation.

We hope you will use the machine safely, and take advantage of its best performance.

Keeping the Owner's Operating Manual

Keep this Owner's Operating Manual in the box located in the rear of the seat.

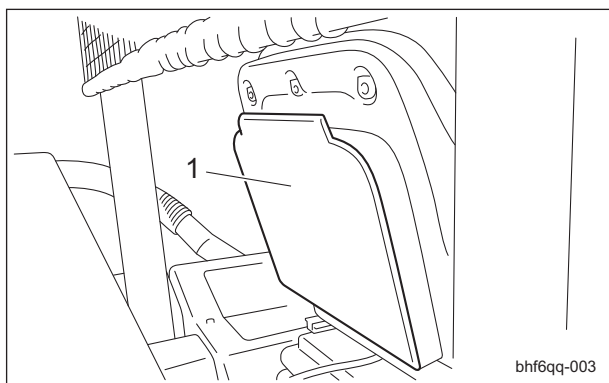

Keeping the Owner's Operating Manual_001

1	Box
---	-----

Read this manual carefully to ensure that you thoroughly understand how to properly operate and maintain this machine, and to avoid causing injury to yourself or others.

The operator is responsible for operating the machine properly and safely.

Do not perform maintenance on the machine other than that described in this manual.

Be sure to also read the operating manuals for the engine, battery, etc.

Maintenance should only be performed by a certified specialist.

If you have any questions concerning maintenance or genuine parts, please contact Kyoisha or your local Baroness dealer.

When making inquiries about this machine, please specify the machine's model designation and serial number.

When loaning or transferring this machine, please also provide the Owner's Operating Manual together with the machine.

Kyoisha Chemical Co., Ltd.

Caution

The information described in this manual is subject to change for improvement without prior notice.

When replacing parts, be sure to use genuine Baroness parts or parts designated by Kyoisha.

Note that the Baroness product warranty may not apply to defects caused by the use of parts from other companies.

Warning Symbols

This manual uses the following warning symbols for handling precautions that are important for your safety.



696cq5-001

Warning symbol

This symbol is accompanied by the word “Danger,” “Warning,” or “Caution.”

All labels with this symbol describe important safety precautions, so please read such labels carefully and only operate the machine after you have understood them completely.

Failure to adequately follow these safety precautions may cause an accident.

Danger

This symbol indicates that serious injury or death will occur if the warning is ignored.

Warning

This symbol indicates that serious injury or death may occur if the warning is ignored.

Caution

This symbol indicates that injury or damage to property may occur if the warning is ignored.

Important

This symbol indicates precautions for setup of the machine.

Introduction

Purpose

This machine is intended for cutting grass at golf courses.

Do not use this machine in any way other than its intended purpose, and do not modify the machine.

Operating this machine for other purposes and modifying it may be very dangerous and may cause damage to the machine.

In addition, this machine is not authorized for operation as a special motor vehicle. Do not operate it on public roads.

Safety..... Page 1-1

Safe Operating Practices..... Page 1-2

Disposal..... Page 2-1

Waste disposal..... Page 2-2

Product Overview..... Page 3-1

Specifications.....Page 3-2

Names of Each Section..... Page 3-3

Safety and Instruction Signs..... Page 3-4

Handling Instructions..... Page 4-1

Inspection Before Use.....Page 4-2

Tightening torques..... Page 4-13

Adjustment Before Operating..... Page 4-16

Procedure to Start / Stop Engine..... Page 4-19

Operation of Each Section..... Page 4-21

Instruments..... Page 4-27

Travel of Machine..... Page 4-29

Cutting Work..... Page 4-30

Transporting..... Page 4-31

Maintenance..... Page 5-1

Maintenance Precautions..... Page 5-2

Maintenance Schedule.....Page 5-2

Jacking up the machine..... Page 5-4

Lubrication..... Page 5-5

Maintenance (Mower)..... Page 5-8

Maintenance (Main Body)..... Page 5-14

Long-Term Storage.....Page 5-18

GM2800B

Contents

Safe Operating Practices..... Page 1-2

Training.....Page 1-2

Preparation..... Page 1-2

Operation..... Page 1-3

Maintenance and storage.....Page 1-4

Safety

Failure to adequately follow these safety precautions may cause an accident resulting in injury or death.

Danger

This machine is designed to ensure safe operation and has been tested and inspected thoroughly before shipment from the factory. The machine is equipped with safety devices to prevent accidents.

However, whether the machine demonstrates its original performance level depends on the manner in which it is operated and handled, as well as the manner in which it is managed on a daily basis.

Inappropriate use or management of the machine may result in injury or death.

Observe the following safety instructions to ensure safe operation.

Safe Operating Practices

The following instructions are taken from CEN standard EN 836: 1997, ISO standard 5395: 1990, and ANSI B71.4-2004.

Training

1. Read the Owner's operating Manual and other training material carefully. Be familiar with the controls, safety signs, and the proper use of the equipment.
2. If the operator or mechanic can not read English it is the owner's responsibility to explain this material to them.
3. All operators and mechanics should seek and obtain professional and practical instruction.

The owner is responsible for training the users.

Such instruction should emphasize.

- [1] The need for care and concentration when working with ride-on machines.
- [2] Control of a ride-on machine sliding on a slope will not be regained by the application of the brake.
The main reasons for loss of control are
 - Insufficient wheel grip
 - Being driven too fast
 - Inadequate braking
 - The type of machine is unsuitable for its task

- Lack of awareness of the effect of ground conditions, especially slopes
- Incorrect hitching and load distribution

4. Never allow untrained personnel to service machine.
Local regulations may restrict the age of the operator.
5. The owner/user can prevent and is responsible for accidents or injuries occurring to themselves, other people, or property.
6. Keep in mind that the owner, operator, and mechanic are responsible for accidents or hazards occurring to other people or their property.

Preparation

1. Evaluate the terrain to determine what accessories and attachments are needed to properly and safely perform the job.
Only use accessories and attachments approved by the manufacturer.
2. While operating, always wear substantial footwear, long trousers, hard hat, safety glasses, and ear protection.
Long hair, loose clothing, or jewelry may get tangled in moving parts.
Do not operate the equipment when barefoot or wearing open sandals.
3. Inspect the area where the equipment is to be used and remove all objects such as rocks, toys and wire which can be thrown by the machine.
4. Exercise care in the handling of fuel.

Warning

Warning-Fuel is highly flammable.
Take the following precautions.

- [1] Store fuel in containers specifically designed for this purpose.
- [2] Add fuel before starting the engine.
Never remove the cap of the fuel tank or add fuel while the engine is running or when the engine is hot.
- [3] Refuel outdoors only and do not smoke while refueling.
- [4] If fuel is spilled, do not attempt to start the engine but move the machine away from the area of spillage and avoid creating any source of ignition until petrol vapours have dissipated.

- [5] Replace all fuel tanks and container caps securely.
- 5. Check that operator's presence controls, safety switches and shields are attached and functioning properly.
Do not operate unless they are functioning properly.
- 6. If the brake operation is faulty or the parking brake lever has noticeable play, be sure to adjust or repair them before operating the machine.
- 7. Replace faulty mufflers.
- 8. Before using, always visually inspect to see that the blades, blade bolts, and cutting assembly are not worn or damaged.
Replace worn or damaged blades and bolts in sets to preserve balance.
- 9. On multi-bladed machines, take care as rotating one blade can cause other blades to rotate.
- [6] Never drive the machine on a slope with an angle of gradient that is greater than that specified or in a place where there is a danger of the machine slipping.
- 5. Never raise deck with the blades running.
- 6. Never operate with the discharge deflector raised, removed or altered, unless using a grass catcher.
Do not crawl under the machine while it is in operation.
- 7. Never operate with the discharge deflector raised, removed or altered, unless using a grass catcher.
- 8. Do not change the engine governor settings or overspeed the engine.
Operating the engine at excessive speed may increase the hazard of personal injury.
- 9. Do the following before leaving the operator's position.

Operation

- 1. Do not operate the engine in a confined space where dangerous carbon monoxide fumes can collect.
- 2. Only operate in good light, keeping away from holes and hidden hazards.
- 3. Before attempting to start the engine, disengage all attachments, shift into neutral, and engage the parking brake.
Only start engine from the operator's position.
Use seat belts if provided.
- 4. Remember there is no such thing as a safe slope.
Travel on grass slopes requires particular care.
To guard against overturning:
 - [1] Do not stop or start suddenly when going up or downhill.
 - [2] Engage clutch slowly, always keep machine in gear, especially when traveling downhill.
 - [3] Machine speeds should be kept low on slopes and during tight turns.
 - [4] Stay alert for humps and hollows and other hidden hazards.
 - [5] Never operate across the face of the slope, unless the machine is designed for this purpose.
- [1] Stop on level ground.
- [2] Disengage the power take-off and lower the attachments.
- [3] Change into neutral and set the parking brake.
- [4] Stop the engine and remove the key.
- 10. Disengage the drive to attachments, stop the engine, and remove the ignition key in the following conditions.
 - [1] Before refueling.
 - [2] Before removing the grass catcher/catchers;
 - [3] Before making height adjustment unless adjustment can be made from the operator's position:
 - [4] Before cleaning blockages.
 - [5] Before checking, cleaning or working the machine.
 - [6] After striking a foreign object or if an abnormal vibration occurs.
Inspect the machine for damage and make repairs before restarting and operating the equipment.
- 11. Keep hands and feet away from the cutting units and the rotating parts.
- 12. Look behind and down before backing up to be sure of a clear path.
- 13. Do not carry passengers.
- 14. Never operate while people, especially children, or pets are nearby.

Safety

15. Slow down and use caution when making turns and crossing roads and sidewalks.
16. Stop the blades rotating before crossing surfaces other than grass.
17. Disengage drive to attachments when transporting or not in use.
18. When using any attachments, never direct discharge of material toward bystanders nor allow anyone near the machine while in operation.
19. Do not operate the machine under the influence of alcohol or drugs.
20. Take care when loading or unloading the machine into a trailer or a truck.
Load or unload the machine in a flat and safe place.
Before loading or unloading, set the parking brake on the truck or trailer, stop the engine, and chock the wheels.
When transporting the machine on a truck or a trailer, set the parking brake, stop the engine, and fasten the machine to the truck with a rope or other suitable restraining device that has sufficient strength.
When using a running board, select one with sufficient strength, length, and width and that will not cause the machine to slip.
21. Close the fuel valve before transporting the machine.
22. Use care when approaching blind corners, shrubs, trees, or other objects that may obscure vision.
23. Do not take your eyes off the road ahead.
Do not operate the machine with no hands.
24. Reduce the throttle setting during engine run-out and, if the engine is provided with a shut-off valve, turn the fuel off at the conclusion of operation.
3. To reduce the fire hazard, keep the engine, silencer/muffler, battery compartment fuel storage area, cutting units and drives free of grass, leaves, or excessive grease.
Clean up oil or fuel spillage.
4. Allow the engine to cool before storing in any enclosure.
5. Only cover the machine with a sheet after hot parts have sufficiently cooled down.
6. Never store the equipment with fuel in the tank inside a building where fumes may reach an open flame or spark.
7. If the engine is provided with a shut-off valve, shut off valve while storing or transporting.
8. Do not store fuel near flames.
9. Never allow untrained personnel to service machine.
10. Allow the engine/muffler to cool before checking/maintenance.
11. Appropriately manage and correctly use the tools necessary for servicing or adjusting the machine.
12. Use jack stands to support components when required.
13. Carefully release pressure from components with stored energy.
14. Be sure to depressurize the hydraulic system before performing maintenance operations on it such as removing hydraulic equipment.
15. Check whether line connectors in the hydraulic system are properly tightened.
Before applying hydraulic pressure, check the connections of the hydraulic pressure lines and the condition of the hoses.
16. When checking the hydraulic circuit for pinhole leaks or oil leakage from nozzles, do not use your hands.
Use items such as paper or corrugated cardboard to find leakage points.
Be extremely careful with high-pressure oil as it may pierce your skin, result.
If fluid is injected into the skin it must be surgically removed within a few hours by a doctor familiar with this form of injury or gangrene may result.

Maintenance and storage

1. Disengage drives on level ground, lower the attachments, set parking brake, stop engine and remove key from ignition.
Wait for all movement to stop before adjusting, cleaning or repairing.
2. When machine is to be parked, stored, or left unattended, lower the cutting units unless a positive mechanical lock is provided.
17. Disconnect battery before making any repairs.
Disconnect the negative terminal first and the positive last.
Reconnect positive first and negative last.

18. Make sure that parts such as wires are not touching each other and that their covers have not come off.
19. Use care when checking the blades.
 - [1] Wrap the blades or wear gloves, and use caution when servicing them.
 - [2] Only replace blades.
 - [3] Never straighten or weld them.
20. On multi-bladed machines, take care as rotating one blade can cause other blades to rotate.
21. Keep hands and feet away from moving parts.
If possible, do not make adjustments with the engine running.
22. Charge batteries in an open well ventilated area, away from spark and flames.
Unplug charger before connecting or disconnecting from battery.
Wear protective clothing and use insulated tools.
23. Keep all parts in good working condition and all hardware tightened.
Replace all worn or damaged decals.
24. Keep all nuts, bolts and screws tight to be sure the equipment is in safe working condition.
25. Check the grass catcher frequently for wear or deterioration.
26. If the fuel tank has to be drained, do this outdoors.

Waste disposal.....Page 2-2

About the Waste disposal.....Page 2-2

Disposal

Waste disposal

About the Waste disposal

Make sure that waste generated when servicing or repairing the machine is disposed of in accordance with local regulations.
(e.g. waste oil, antifreeze batteries, rubber products, and wires etc.)

Specifications..... Page 3-2

Specifications.....	Page 3-2
Sound pressure level.....	Page 3-2
Sound power level.....	Page 3-2
Vibration level.....	Page 3-3

Names of Each Section..... Page 3-3

Serial Number Plate.....	Page 3-3
Specification Decal.....	Page 3-4
Noise Emission Decal.....	Page 3-4
Year of Manufacture Decal.....	Page 3-4
Maintenance Decal.....	Page 3-4

Safety and Instruction Signs..... Page 3-4

About the Safety and Instruction Signs	Page 3-4
Positions of the Decals (Warning and Instruction)	Page 3-5
Warning and Instruction Decals.....	Page 3-6

Product Overview

Specifications

Specifications

Model		GM2800B	
Dimensions	Total length		370 cm
	Total width	During operation	300 cm
		During transport	230 cm
	Total height	Roof	230 cm
Handle		165 cm	
Weight		2,030 kg	
Minimum turning radius		320 cm	
Engine	Model		Kubota V2403-M-T
	Type		Vertical water-cooled 4-cycle diesel engine with turbocharger
	Total displacement		2,434 cm ³ (2.433 L)
	Maximum output		41.7 kW (56.7 PS)/2,600 rpm
Fuel tank capacity		Diesel 51.0 dm ³ (51.0 L)	
Fuel consumption		208 g/kW.h (rated output)	
Quantity of engine oil		10.0 dm ³ (10.0 L)	
Mowing width		280 cm	
Mowing height		20 - 91.5 mm	
Drive		HST, 2WD/4WD selectable	
Speed (HST)	Forward	0 - 16.0 km/h	
	Reverse	0 - 9.0 km/h	
Speed (Mechanical)		-	
Efficiency		20,160 m ² /h (9.0 km/h x mowing width x 0.8)	
Maximum inclination for operation		15 degrees	
Tire size	Front wheel	29 x 14.00 - 15	
	Rear wheel	20 x 12.00 - 10	
Tire pneumatic pressure	Front wheel	150 kPa (1.5 kgf/cm ²)	
	Rear wheel	140 kPa (1.4 kgf/cm ²)	
Battery		105D31R	

* The factory default maximum engine rpm is 2,400 rpm.

Sound pressure level

Sound pressure

This machine was confirmed to have a continuous A-weighted sound pressure level of 89dB by measuring identical machines in accordance with the procedure specified in CEN EN836:1997.

Sound power level

Sound power

This machine was confirmed to have a sound power level of 105dB by measuring identical machines in accordance with the procedure specified in directive 2000/14/EC.

Vibration level

Hand-arm vibration

This machine was confirmed to transmit a maximum vibration level of less than 2.5 m/s^2 to hands and arms by measuring identical machines in accordance with the procedure specified in ISO5349-1:2001-5349-2:2001.

Whole body vibration

This machine was confirmed to transmit a maximum vibration level of less than 1.27 m/s^2 to the whole body by measuring identical machines in accordance with the procedure specified in ISO2631-1:1997-2631:2003.

Names of Each Section

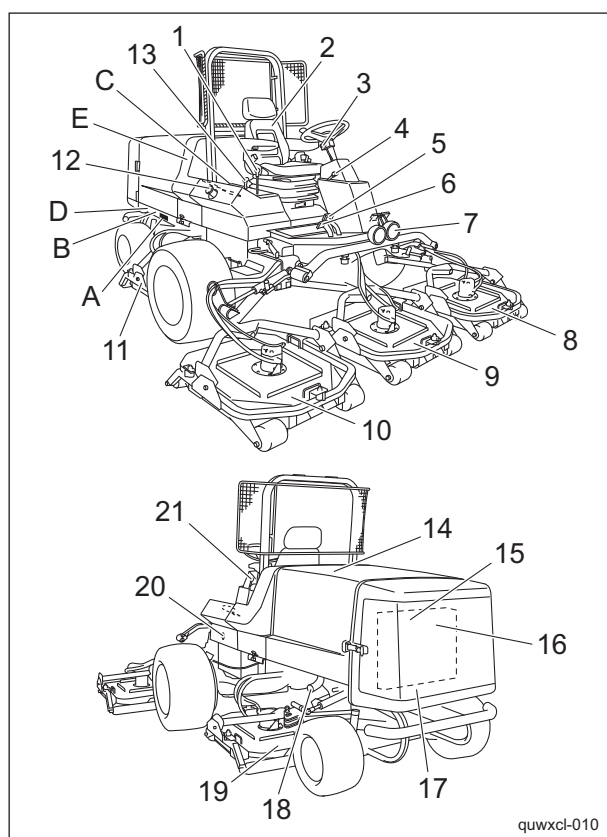

Names of Each Section_002

1	Mower unit up/down lever
2	Seat
3	Diff-lock switch
4	Tilt lever
5	Forward pedal
6	Reverse pedal
7	Lights
8	Mower unit #5
9	Mower unit #1
10	Mower unit #4
11	Mower unit #2
12	Fuel filler
13	Throttle lever
14	Hood
15	Radiator
16	Oil cooler
17	Radiator cover
18	Muffler
19	Mower unit #3
20	Oil gauge
21	Parking brake lever
A	Serial number plate
B	Decal, specifications
C	Decal, noise emission
D	Decal, year of manufacture
E	Decal, maintenance

Serial Number Plate

The serial number plate indicates the name and serial number of the machine.

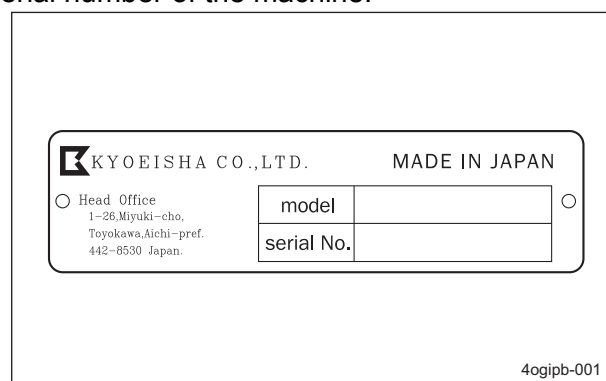

Serial Number Plate_001

Product Overview

Specification Decal

The Specification decal indicates the CE logo, model name, and weight, etc.

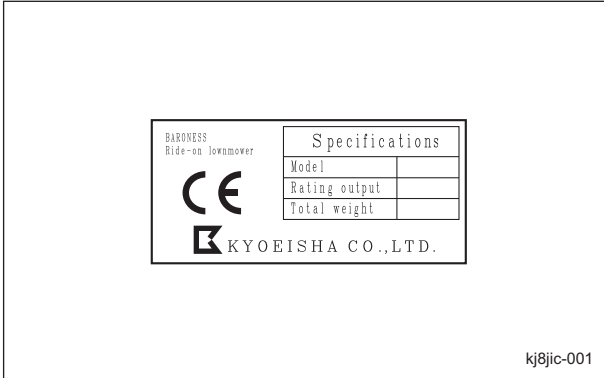

Decal, Specifications_001

Noise Emission Decal

The noise emission decal indicates the sound power level determined by measuring identical machines in accordance with the procedure specified in the EC directives.

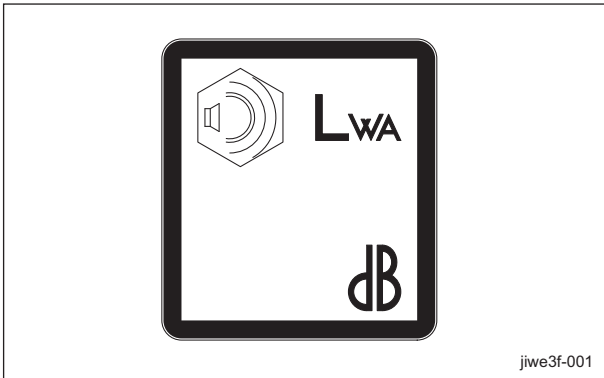

Noise Emission Decal_001

Year of Manufacture Decal

The year of manufacture decal indicates the year when this machine was manufactured.



Year of Manufacture Decal_001

Maintenance Decal

The maintenance decal indicates the necessary inspection and maintenance items for this machine.

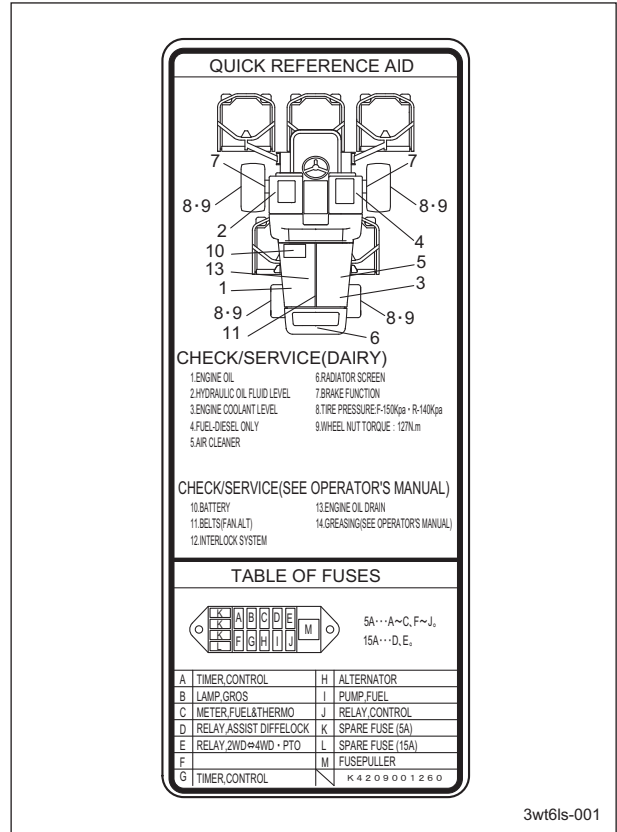

Maintenance Decal_001

Safety and Instruction Signs

About the Safety and Instruction Signs

Warning

Safety labels and operation labels are attached to this machine. Make sure that they are preserved in their entirety. If they are damaged, become dirty, or peel off, replace them with new ones.

Part numbers for labels that need to be replaced are listed in the parts catalog. Order them from a Baroness dealer or Kyoeisha.

Positions of the Decals (Warning and Instruction)

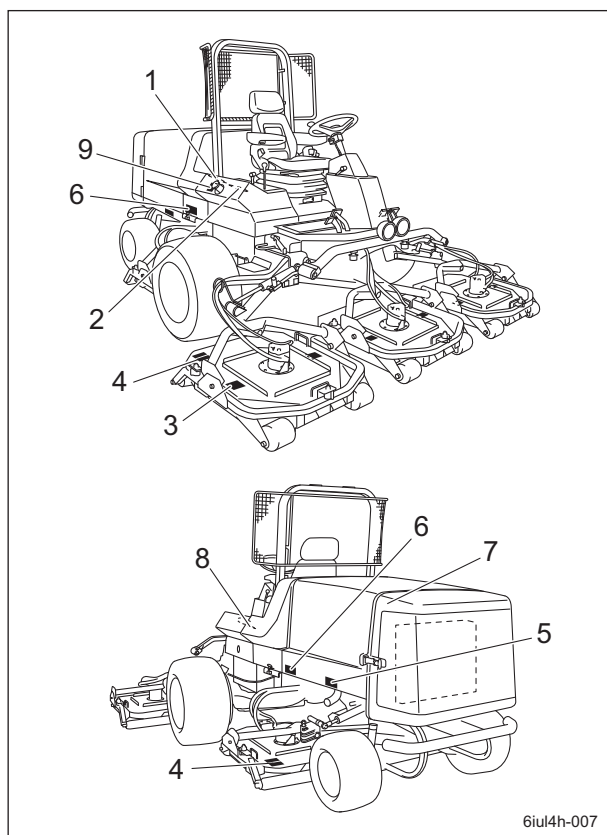



Positions of the Decals (Warning and Instruction)_001

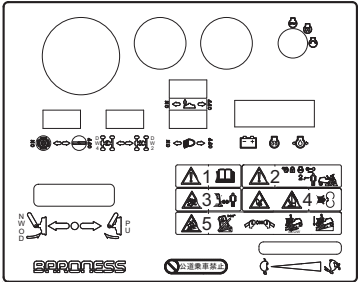
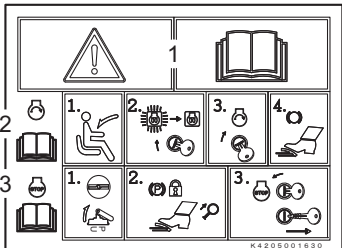

Product Overview

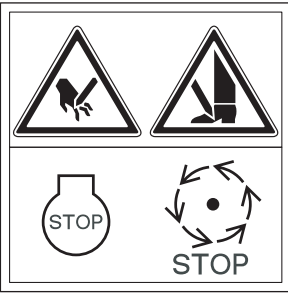
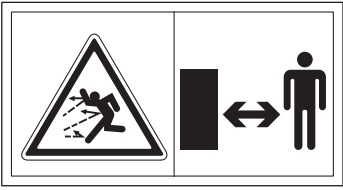
Warning and Instruction Decals

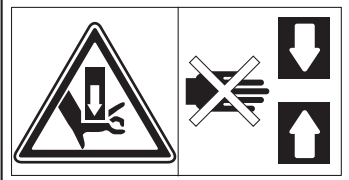
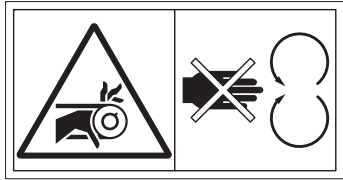
<p>1</p>  <p>qigqnx-032</p>	<p>GM2800-0941Z0 Decal, operation</p> <ol style="list-style-type: none"> Warning Read the Owner's Operating Manual. Warning Apply the parking brake, stop the engine, remove the ignition key, and then leave the machine. Danger Flying objects - All persons other than the operator must keep a safe distance from the machine. Danger May cut your hand or leg - Keep hands and feet away from moving parts. Danger Rollover - Do not work on slopes of 15 degrees or more. When you descend a slope, fasten your seatbelt, lower the mower units, and then drive at low speed.
<p>2</p>  <p>qigqnx-033</p>	<p>K4205001630 Decal, start/stop engine</p> <ol style="list-style-type: none"> Warning Read the Owner's Operating Manual. Procedure to Start Engine Read the Owner's Operating Manual. [1] Sit on the seat. [2] Turn the key to the "GLOW" position, and then wait for the thermo-start lamp to turn off. [3] Turn the key to the "START" position. [4] Depress the brake pedal to release the parking brake. Procedure to Stop Engine [1] Set the knife rotation switch to the "OFF" position, and then raise the mower units. [2] Apply the parking brake. [3] Turn the key to the "STOP" position, and then remove it.

3	 <p style="text-align: center;">qiqqnx-010</p>	<p>K4205001600 Decal, caution for severe injury</p> <p>⚠ Danger</p> <p>May cut your hand or leg - Stop the rotation and engine. Otherwise you may get injured.</p>
4	 <p style="text-align: center;">qiqqnx-011</p>	<p>K4205001650 Decal, caution for flying object</p> <p>⚠ Danger</p> <p>Caution for flying object - When the blades are rotating, keep away from the machine. All bystanders must keep a safe distance from the machine.</p>
5	 <p style="text-align: center;">qiqqnx-034</p>	<p>K4205001780 Decal, caution for hand or leg injury</p> <p>⚠ Danger</p> <p>May cut your hand or leg - When the blades are rotating, keep away from the machine.</p>
5	 <p style="text-align: center;">K4205001540 qiqqnx-022</p>	<p>K4205001540 Decal, caution for high temperature</p> <p>⚠ Caution</p> <p>High temperature - Do not touch. Otherwise, you will be burned.</p>
6	 <p style="text-align: center;">qiqqnx-035</p>	<p>K4205001580 Decal, caution for pinching</p> <p>⚠ Caution</p> <p>May pinch - There is a risk of being pinched.</p>
7	 <p style="text-align: center;">qiqqnx-012</p>	<p>K4205001530 Decal, caution for rotating object</p> <p>⚠ Danger</p> <p>Watch for rotating parts - Keep your hands away from the belts while the engine is running.</p>

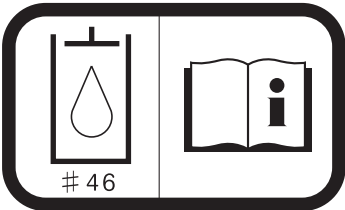
Product Overview

8	 <p># 46</p> <p>K4209000980</p> <p>qigqnx-020</p>	<p>K4209000980</p> <p>Hydraulic oil icon</p> <p>Read the Owner's Operating Manual.</p>
9	 <p>K4209001000</p> <p>qigqnx-021</p>	<p>K4209001000</p> <p>Fuel icon</p> <p>Use No. 2 diesel fuel. (Low sulfur or ultra-low sulfur diesel fuel only)</p>

Handling Instructions

Inspection Before Use.....	Page 4-2	Traction Assist Switch.....	Page 4-23
Rotary Knife.....	Page 4-2	Mower Lock Lever (Latch).....	Page 4-23
Radiator Cover.....	Page 4-2	Mower Unit Up/Down Lever.....	Page 4-24
Radiator.....	Page 4-3	Throttle Lever.....	Page 4-24
Coolant.....	Page 4-3	Diff-Lock Switch.....	Page 4-25
Oil cooler.....	Page 4-5	Traveling Pedal.....	Page 4-25
Hydraulic oil.....	Page 4-5	Brake Pedal.....	Page 4-25
Air cleaner.....	Page 4-7	Parking Brake Lever.....	Page 4-26
Battery.....	Page 4-8	Hood.....	Page 4-27
Tire.....	Page 4-9	Underseat Cover.....	Page 4-27
Brake.....	Page 4-9	Instruments.....	Page 4-27
Belt.....	Page 4-9	Instruments on the Operation Panel.....	Page 4-27
Around the Engine.....	Page 4-9	Tachometer/Hour Meter.....	Page 4-28
Engine oil.....	Page 4-9	Water Temperature Gauge.....	Page 4-28
Fuel.....	Page 4-11	Fuel Gauge.....	Page 4-28
Oil Leakage.....	Page 4-12	Pilot Lamps.....	Page 4-29
Tightening torques.....	Page 4-13	Travel of Machine.....	Page 4-29
Standard tightening torques.....	Page 4-13	Moving the Machine.....	Page 4-29
Principal tightening torques	Page 4-14	Towing the Machine.....	Page 4-29
Adjustment Before Operating.....	Page 4-16	Cutting Work.....	Page 4-30
Adjustment of Steering Wheel.....	Page 4-16	Cutting Operation.....	Page 4-30
Adjustment of Seat.....	Page 4-16	Transporting.....	Page 4-31
Adjustment of Cutting Height.....	Page 4-17	Transporting Procedure.....	Page 4-31
Procedure to Start / Stop Engine.....	Page 4-19		
Start / Stop of Engine.....	Page 4-19		
Safety Mechanisms.....	Page 4-20		
Warning Mechanisms.....	Page 4-20		
Operation of Each Section.....	Page 4-21		
Precautions for Operating the Machine			
.....	Page 4-21		
Cautions for when You Leave the Machine			
.....	Page 4-21		
Instruction Decals.....	Page 4-21		
Proximity Sensors.....	Page 4-21		
Relays.....	Page 4-21		
Knife Rotation Switch.....	Page 4-22		
2WD/4WD Selector Switch.....	Page 4-22		
Light Switch.....	Page 4-23		

Handling Instructions

Inspection Before Use

Be sure to perform an inspection before you start using the machine so that you will be able to take advantage of its optimum performance for a long period of time.

Rotary Knife

Inspection of Rotary Knife

⚠ Danger

The rotary knife is an edged tool. Handle them carefully, since they could cut your hands or legs.

⚠ Caution

When touching edged tools, wear gloves, since they could cut your hands.

Due to frequent use, objects crushed during mowing, or damage during transportation and so forth, the rotary knife may vibrate from imbalance or become dull. Inspect the rotary knife, and if necessary, sharpen, balance or replace it.

Important

Frequently inspect the rotary knife since it may become dull quickly if the machine is operated in an environment of dry soil or sand.

1. Make sure that the rotary knife is not bent.
2. Make sure that the rotary knife is not chipped.
3. Check to see how much the rotary knife is worn.
4. Make sure that the rotary knife is not worn asymmetrically.
5. Make sure that the mounting bolt for the rotary knife is not loose.

6. Make sure that there are no cracks or tears between the sail and flat part of the rotary knife.

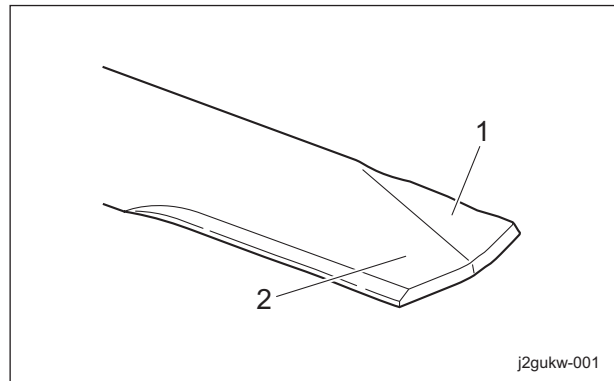

Inspection of Rotary Knife_001

1	Sail
2	Flat part

Radiator Cover

Inspection of Radiator Cover

1. Make sure that there is no damage to the radiator cover.
2. Make sure that the radiator cover is not contaminated.

Cleaning of Radiator Cover

Important

An unclean radiator cover may cause overheating or damage to the engine. It may also cause malfunction of the hydraulic system.

If the radiator cover has been contaminated with dust, be sure to clean it. After operating the machine in a dusty environment, it is important to remove dust from the cover as soon as possible.

1. Open the radiator cover.

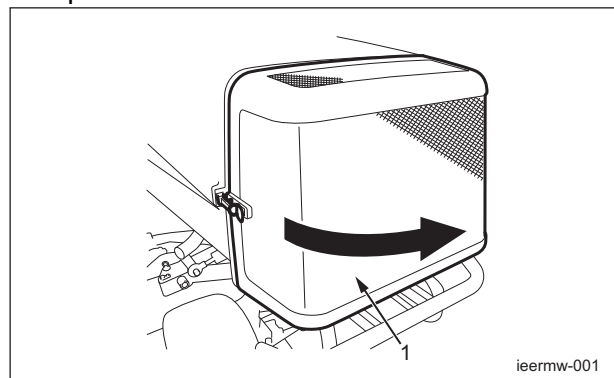

Cleaning of Radiator Cover_001

Handling Instructions

1	Radiator cover
---	----------------

- Carefully clean the front and back of the radiator cover with water or compressed air.

Radiator

Inspection of Radiator

For details on handling the engine, please refer to the separate Engine Operating Manual.

- Make sure that there is no damage to the radiator.
- Make sure that the radiator is not contaminated.

Cleaning of Radiator

For details on handling the engine, please refer to the separate Engine Operating Manual.

Important

An unclean radiator may cause overheating or damage to the engine. It may also cause malfunction of the hydraulic system.

Important

Do not use solid objects, such as a spatula or screwdriver, or high-pressure water to clean the radiator or oil cooler. Otherwise, special fins or tubes may be damaged, possibly resulting in reduced cooling performance or coolant leakage.

If the radiator has been contaminated with dust, be sure to clean it. After operating the machine in a dusty environment, it is important to remove dust as soon as possible.

- Open the radiator cover.

- Unlock the rubber catches on the left and right of the oil cooler, and then tilt the oil cooler.

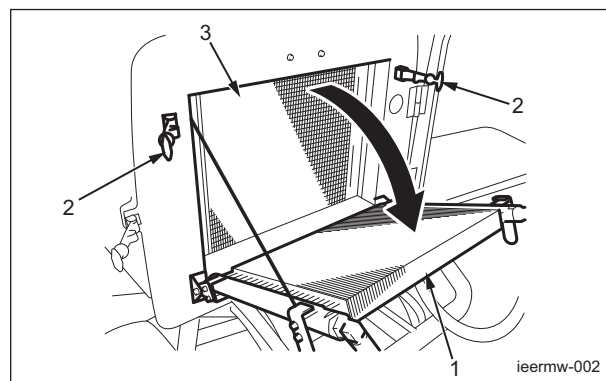

Cleaning of Radiator_001

1	Oil cooler
2	Rubber catch
3	Radiator

- Carefully clean the front and back of the radiator with water or compressed air.

Coolant

Inspection of Coolant

For details on handling the engine, please refer to the separate Engine Operating Manual.

Warning

Do not touch the radiator or coolant during engine operation or right after the engine has been turned off. Due to high temperatures, doing so could cause burns.

Caution

Inspection should take place after the engine has well cooled down.

- Make sure that the coolant level in the reserve tank is between "Full" and "Low."

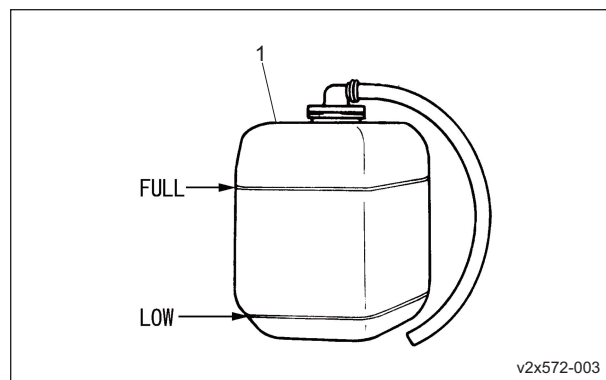

Inspection of Coolant_001

Handling Instructions

1 Reserve tank

Coolant Supply

For details on handling the engine, please refer to the separate Engine Operating Manual.

Warning

Do not touch the radiator or coolant during engine operation or right after the engine has been turned off.

Due to high temperatures, doing so could cause burns.

After the radiator has well cooled down, open the radiator cap.

Caution

Supply coolant after the engine has well cooled down.

Caution

The radiator cap is pressurized.

If you remove the radiator cap while the engine is overheated, hot steam will burst out, possibly resulting in burns.

Make sure that the water temperature and pressure are reduced, and then grab the cap with a thick cloth and gradually open the cap.

Important

When you supply coolant, be sure to use clean water, such as tap water.

During winter, remove coolant. Alternatively, mix long-life coolant and clean water, and then pour it into the radiator and reserve tank.

Relationship between concentration of long-life coolant (LLC) and freezing temperature

Freezing temperature	LLC concentration (volume %)
Down to -10 °C (14 °F)	20%
Down to -15 °C (5°F)	30%
Down to -20 °C (-4 °F)	35%
Down to -25 °C (-13 °F)	40%

1. If the coolant level in the reserve tank is lower than the "LOW" mark, open the reserve tank cap and fill the tank with clean water up to the "FULL" mark.

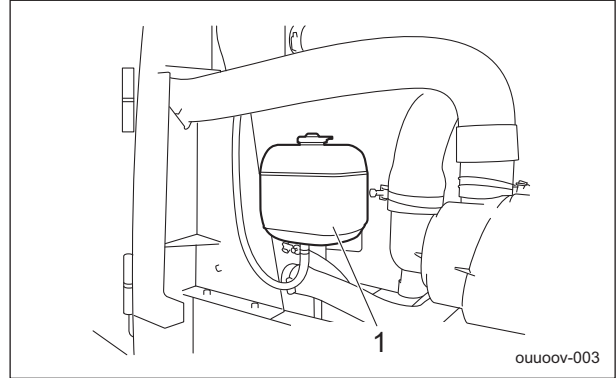

Coolant Supply_001

1 Reserve tank

2. If no coolant is in the reserve tank, follow the steps below to fill the tank with clean water.

[1] Open the radiator cap, and then supply clean water up to the opening.

[2] Open the reserve tank cap, and then supply clean water up to the "FULL" mark.

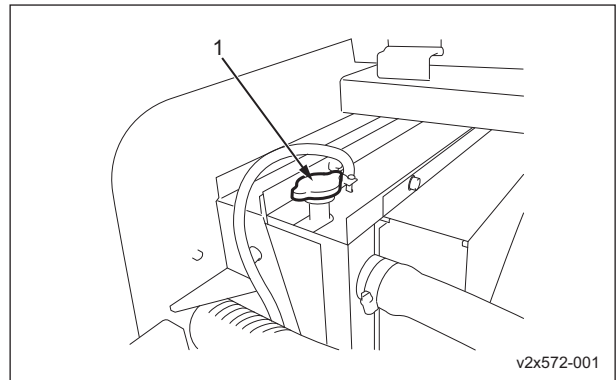

Coolant Supply_002

1 Radiator cap

Change of Coolant

For details on handling the engine, please refer to the separate Engine Operating Manual.

Warning

When you change the coolant, be sure to drain it into a bowl and discard it in accordance with local laws and regulations.

Handling Instructions

Warning

Do not touch the radiator or coolant during engine operation or right after the engine has been turned off.

Due to high temperatures, doing so could cause burns.

After the radiator has well cooled down, open the radiator cap.

Caution

Change coolant after the engine has well cooled down.

Important

When you change coolant, be sure to use clean water, such as tap water.

During winter, remove coolant. Alternatively, mix long-life coolant and clean water, and then pour it into the radiator and reserve tank.

For details on changing coolant, please refer to the separate Engine Operating Manual.

Coolant quantity, including the reserve tank, is 12.0 dm³ (12.0 L).

Oil cooler

Inspection of Oil Cooler

1. Make sure that there is no damage to the oil cooler.
2. Make sure that the oil cooler is not contaminated.

Cleaning of Oil Cooler

Caution

An unclean oil cooler may cause overheating or damage to the engine. It may also cause malfunction of the hydraulic system.

Important

Do not use solid objects, such as a spatula or screwdriver, or high-pressure water to clean the radiator or oil cooler.

Otherwise, special fins or tubes may be damaged, possibly resulting in reduced cooling performance or coolant leakage.

If the oil cooler has been contaminated with dust, be sure to clean it. After operating the machine in a dusty environment, it is important to remove dust as soon as possible.

1. Open the radiator cover.
2. Unlock the rubber catches on the left and right of the oil cooler, and then tilt the oil cooler.

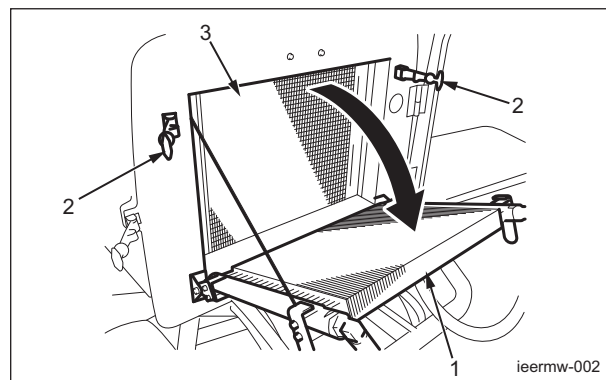

Cleaning of Oil Cooler_001

1	Oil cooler
2	Rubber catch
3	Radiator

3. Carefully clean the front and back of the oil cooler with water or compressed air.

Hydraulic oil

Inspection of Hydraulic Oil

1. Raise the mower units and maintain that position on a level surface.
2. Make sure that the oil level is at the middle of the oil gauge.

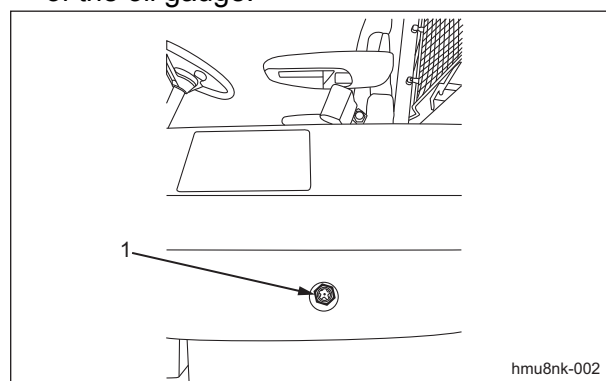

Inspection of Hydraulic Oil_001

1	Oil gauge
---	-----------

3. Check underneath the machine for oil leakage.

Handling Instructions

Hydraulic Oil Supply

Important

Do not mix different types of oil.

Important

Use Shell Tellus S2M46 (or equivalent) as hydraulic oil.

1. If the oil level is low, remove the left tank cover, and then open the tank cap and supply oil.

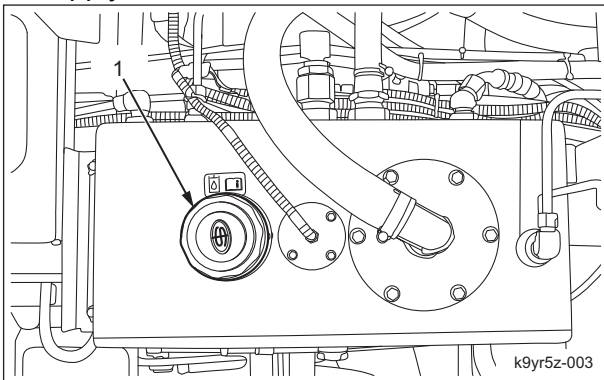

Hydraulic Oil Supply_001

1	Tank cap
---	----------

2. Start the engine, raise and lower the mower units, and turn the steering wheel left and right. Move forward and reverse repeatedly several times.
3. Raise the mower units and maintain that position on a level surface, and then check to see if the oil level is at the middle of the oil gauge. If necessary, supply oil.
4. Check underneath the machine for oil leakage.
5. Attach the left tank cover.

Change of Hydraulic Oil

Warning

When you change the hydraulic oil, be sure to drain it into a bowl and discard it in accordance with local laws and regulations.

Caution

If the oil emulsifies or if it becomes even slightly less transparent, change the oil immediately.

Important

Use Shell Tellus S2M46 (or equivalent) as hydraulic oil.

1. Follow the steps below to remove the old oil.
 - [1] Start and run the engine to warm up the oil. On a level surface, remove the drain plug on the hydraulic tank, and then drain the old oil into a container.
 - [2] Wind new sealing tape on the drain plug, and then attach it to the hydraulic tank.

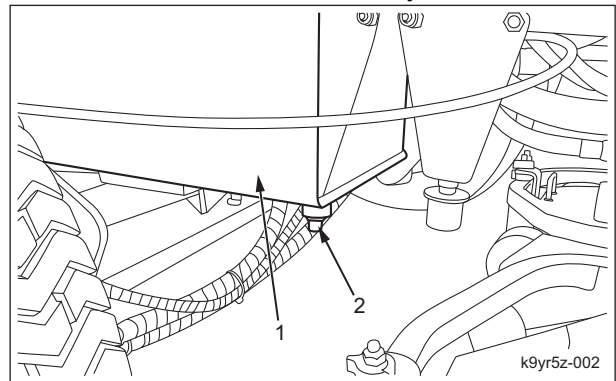

Change of Hydraulic Oil_001

1	Hydraulic tank
2	Drain plug

2. Remove the left tank cover, open the tank cap, pour new oil from the fill port until the oil level reaches the middle of the oil gauge on the hydraulic tank, and then re-place the tank cap. The hydraulic tank capacity is approximately 44.0 dm³ (44.0 L).

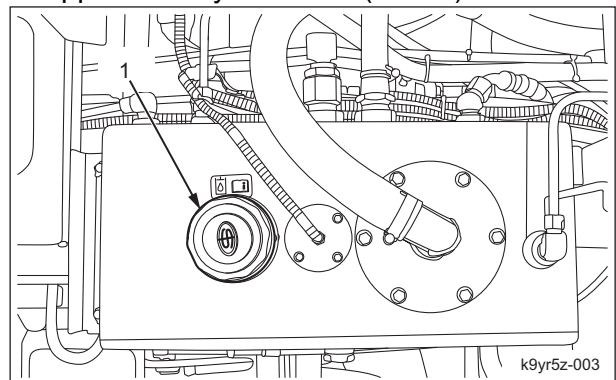

Change of Hydraulic Oil_002

Handling Instructions

1	Tank cap
---	----------

3. Start the engine, raise and lower the mower units, and turn the steering wheel left and right.
Move forward and reverse repeatedly several times.
4. Raise the mower units and maintain that position on a level surface, and then check to see if the oil level is at the middle of the oil gauge. If necessary, supply oil.
5. Check underneath the machine for oil leakage.
6. Attach the left tank cover.

Air cleaner

Inspection of Air Cleaner

For details on handling the engine, please refer to the separate Engine Operating Manual. The air cleaner is a component that removes dirt from the intake air to prevent wear of the cylinder liners and piston rings so that the engine will always operate smoothly. A contaminated air cleaner element may cause malfunction of the engine.

1. Inspect the air cleaner by checking the vacuum indicator.
If the air cleaner element is contaminated, the vacuum indicator will display a red ring.

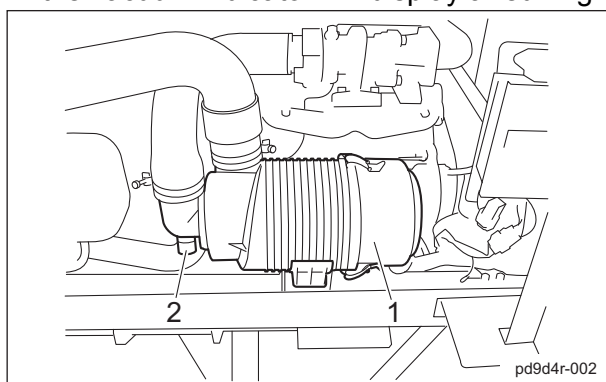

Inspection of Air Cleaner_001

1	Air cleaner
2	Vacuum indicator

2. Make sure that there is no damage to the air cleaner.

Cleaning of Air Cleaner

For details on handling the engine, please refer to the separate Engine Operating Manual.

A contaminated air cleaner element may cause malfunction of the engine. To maximize the life of the engine, clean the air cleaner properly.

1. Follow the steps below to clean the air cleaner.
 - [1] Remove the clips from the two locations, remove the air cleaner cap, and then remove the air cleaner element.
 - [2] While paying close attention not to damage the air cleaner element, tap a solid portion of the air cleaner element or blow air from its inside to remove dust and dirt.
If the air cleaner element is extremely contaminated, replace it with a new one.
 - [3] Attach the air cleaner element to the air cleaner body.
 - [4] Re-place the air cleaner cap, and then affix it securely using the clips.

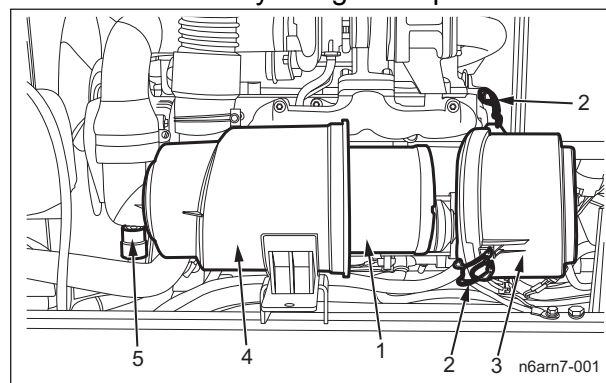

Cleaning of Air Cleaner_001

1	Air cleaner element
2	Clip
3	Air cleaner cap
4	Air cleaner body
5	Vacuum indicator

2. Press the reset button for the vacuum indicator.

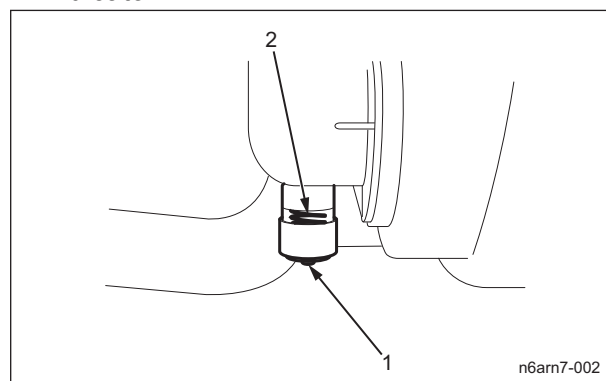

Cleaning of Air Cleaner_002

Handling Instructions

1	Reset button
2	Vacuum indicator

Change of Air Cleaner

For details on handling the engine, please refer to the separate Engine Operating Manual. A contaminated air cleaner element may cause malfunction of the engine.

To maximize the life of the engine, replace the air cleaner element at the appropriate times.

1. The timing for replacing the air cleaner element is described below.
 - [1] Replace the air cleaner element in accordance with the Maintenance Schedule.
 - [2] If it is significantly contaminated, replace it, even if the hours of operation do not exceed the recommended number of hours.
 - [3] Even if the hours of operation do not exceed the recommended number of hours, change it at least once per year.
2. Replace the air cleaner element by following the same steps for cleaning the air cleaner. (See "Cleaning of Air Cleaner" (Page 4-7) .)

Battery

For details on handling the battery, refer to the instruction manual provided with it.

Inspection of Battery

For details on handling the battery, please refer to the separate Battery Instruction Manual.

⚠ Danger

Keep fire away while inspecting or charging the battery.
The battery may explode.

⚠ Warning

Do not allow the battery fluid level to become lower than the LOWER LEVEL (minimum fluid level line) .
The battery may explode if it is used or charged while the battery fluid level is at the LOWER LEVEL (minimum fluid level line) .

1. Clean the areas around the battery fluid level lines using a cloth damp with water.

2. Make sure that the battery fluid level is between the UPPER LEVEL (maximum fluid level line) and the LOWER LEVEL (minimum fluid level line).

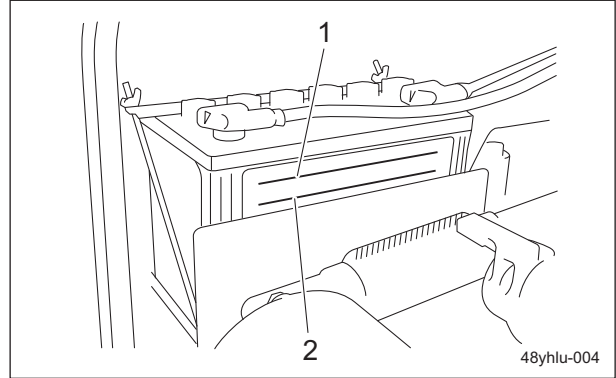

Inspection of Battery_001

1	UPPER LEVEL
2	LOWER LEVEL

Supply of Battery Fluid

For details on handling the battery, please refer to the separate Battery Instruction Manual.

⚠ Danger

Be careful not to let your skin, eyes or clothes, etc., come into contact with battery fluid (electrolyte) or accidentally swallow the fluid.

Should your skin or clothes come into contact with electrolyte, immediately wash them away with water.

⚠ Warning

When you supply battery fluid, wear protective garments and safety glasses, etc.

Handling Instructions

- If the battery fluid level is lower than halfway between the UPPER LEVEL (maximum) line and LOWER LEVEL (minimum) line, add purified water up to the UPPER LEVEL (maximum) line.

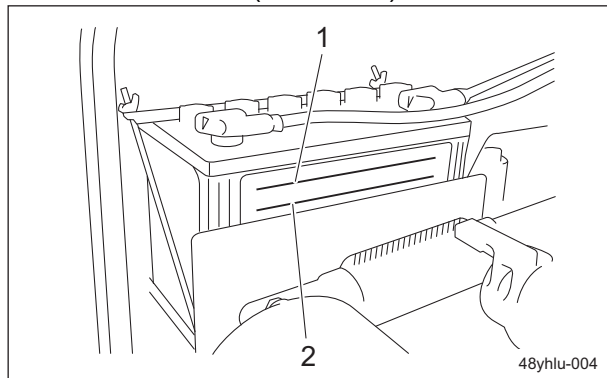

Supply of Battery Fluid_001

1	UPPER LEVEL
2	LOWER LEVEL

Tire

Inspection of Tires

- Check the pneumatic pressure of the tires.
- Make sure that there are no cracks, damage or abnormal wear.

Tire size	Pneumatic pressure
Front wheel (29 x 14.00 - 15)	150 kPa (1.5 kgf/cm ²)
Rear wheel (20 x 12.00 - 10)	140 kPa (1.4 kgf/cm ²)

Brake

Inspection of Brake

While traveling, depress the brake pedal firmly to make sure that the brake is applied effectively.

Inspection of Parking Brake

- Make sure that the brake is applied when you pull the parking brake lever.
- Make sure that the brake is not applied even slightly after you depress the brake pedal to release the parking brake lever.

Belt

Inspection of Belt

Caution

If you have removed the shield during inspection, make sure that you re-attach it in the original position securely. If the shield remains removed, the operator may come in contact with the fan or belt, possibly resulting in injuries.

Important

A slacking or damaged belt or damaged fan may cause overheating or lack of a battery charge.

- Press the middle of the belt with your finger to check the belt tension.
- Make sure that there are no cracks, damage or abnormal wear.

Around the Engine

Inspection of Engine-Associated Parts

For details on handling the engine, please refer to the separate Engine Operating Manual.

- Check the fuel system parts for loosened or cracked joints and leakage. Replace the parts if necessary.
- Blow compressed air to clean any grass or flammable materials that may be attached inside or around the muffler.

Engine oil

Inspection of Engine Oil

Important

Securely tighten the oil level gauge and oil filler cap. If they are insufficiently tightened or there is an insufficient seal, negative pressure inside the crankcase cannot be maintained, causing the oil to rise, possibly resulting in the production of white smoke and damage to the engine.

- Stop the engine, wait for 10 to 20 minutes for the engine to cool down, and then check the oil level.

Handling Instructions

- Position the machine so that the engine will be level, and then insert the oil level gauge all the way to check the oil level.

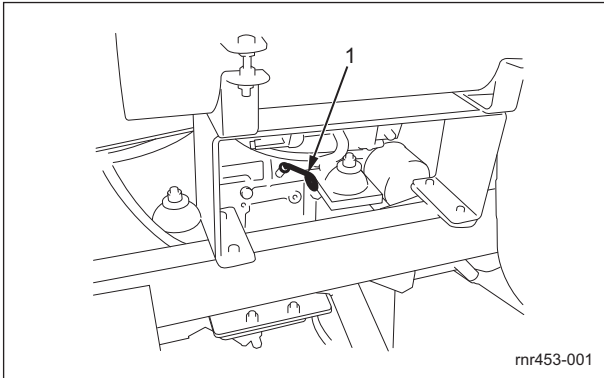

Inspection of Engine Oil_001

1	Oil gauge
---	-----------

- The appropriate oil level should be between the upper and lower limit lines on the gauge.

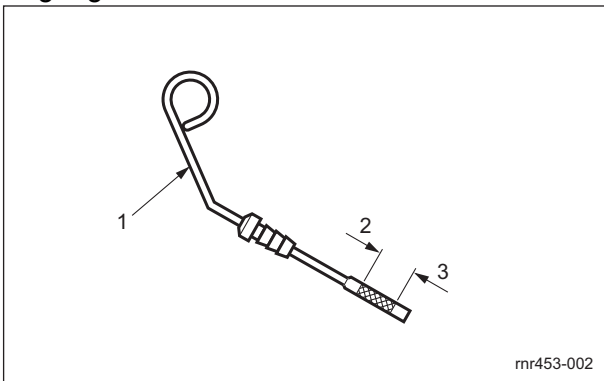

Inspection of Engine Oil_002

1	Oil level gauge
2	Upper limit
3	Lower limit

Supply of Engine Oil

For details on handling the engine, please refer to the separate Engine Operating Manual.

Important

Do not fill too much engine oil. Otherwise, the engine may be damaged.

Important

Do not mix different types of engine oil.

Important

Be sure to use engine oil that is classified as API Service Grade CF or higher, with an SAE Viscosity that is appropriate for the operating environment (ambient temperature).

Important

Securely tighten the oil level gauge and oil filler cap. If they are insufficiently tightened or there is an insufficient seal, negative pressure inside the crankcase cannot be maintained, causing the oil to rise, possibly resulting in the production of white smoke and damage to the engine.

- If the engine oil level is lower than the lower limit line on the oil level gauge, supply engine oil through the oil filling port. Remove the oil filler cap, and then supply new engine oil until the oil reaches a level in between the upper and lower limit lines on the oil level gauge.
- Re-place the oil filler cap.

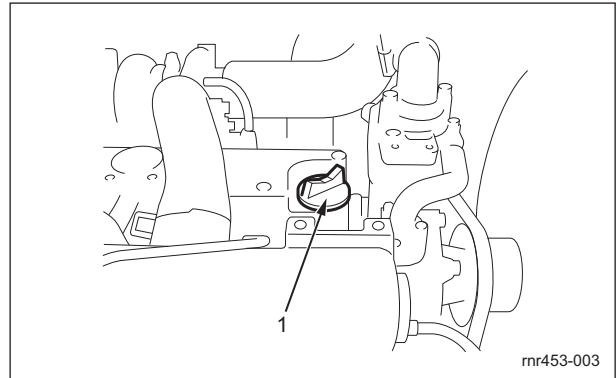

Supply of Engine Oil_001

1	Oil filler cap
---	----------------

- It will take a while for the supplied engine oil to descend into the oil pan. Check the oil level again 10 to 20 minutes after supplying the oil.

Change of Engine Oil

For details on handling the engine, please refer to the separate Engine Operating Manual.

Warning

When you change the engine oil, be sure to drain it into a bowl and discard it in accordance with local laws and regulations.

Handling Instructions

⚠ Caution

Be careful with hot oil, which could cause burns if it contacts your skin.

Important

Be sure to use engine oil that is classified as API Service Grade CF or higher, with an SAE Viscosity that is appropriate for the operating environment (ambient temperature).

Important

Securely tighten the oil level gauge and oil filler cap. If they are insufficiently tightened or there is an insufficient seal, negative pressure inside the crankcase cannot be maintained, causing the oil to rise, possibly resulting in the production of white smoke and damage to the engine.

Change the engine oil more frequently, if the engine oil is contaminated, and especially if you use the machine in dusty areas or operate the engine at high loads or in high temperatures.

1. Move the machine onto a level surface, stop the engine, remove the drain plug while the engine oil is warm, and then drain the oil into a bowl.
2. Re-place the drain plug in the engine.

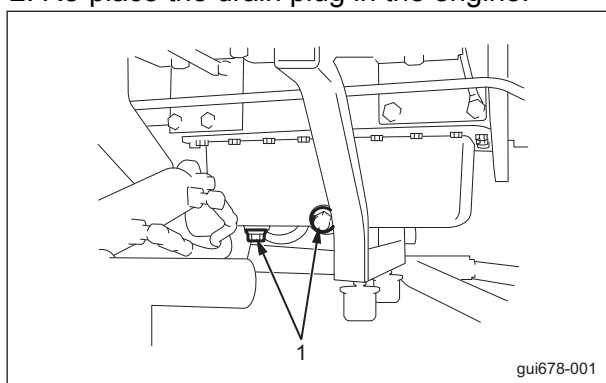

Change of Engine Oil_001

1	Drain plug
---	------------

3. Through the oil filling port, supply new engine oil until the oil reaches a level in between the upper and lower limit lines on the oil level gauge. Engine oil quantity is approximately 10.0 dm³ (10.0 L).

4. Re-place the oil filler cap.

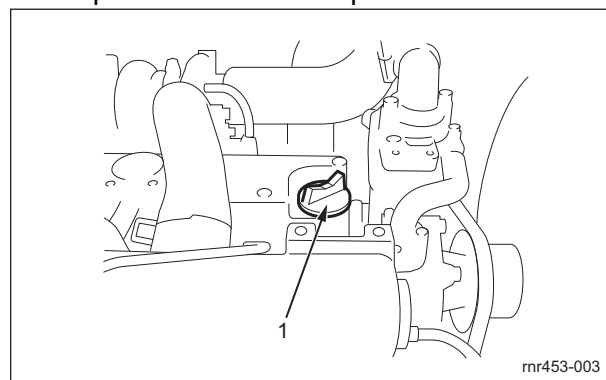

Change of Engine Oil_002

1	Oil filler cap
---	----------------

5. It will take a while for the supplied engine oil to descend into the oil pan. Check the oil level again 10 to 20 minutes after supplying the oil.

Fuel

Inspection of Fuel Quantity

Observe the fuel gauge in the operation panel to check the fuel level.

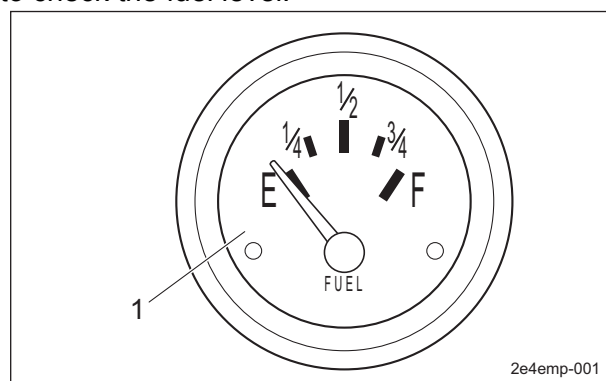

Inspection of Fuel Quantity_001

1	Fuel gauge
---	------------

Fuel Supply

⚠ Danger

Do not supply fuel above F (FULL) level of the fuel gauge. If you supply too much fuel, it might overflow from the fuel cap when you travel or work on a slope.

⚠ Warning

Keep fire away while refueling. Do not smoke while refueling.

Handling Instructions

If the fuel gauge located in the upper right corner of the operation panel indicates a level close to E (EMPTY), supply fuel (diesel) at your earliest convenience.

The fuel tank capacity is approximately 51.0 dm³ (51.0 L).

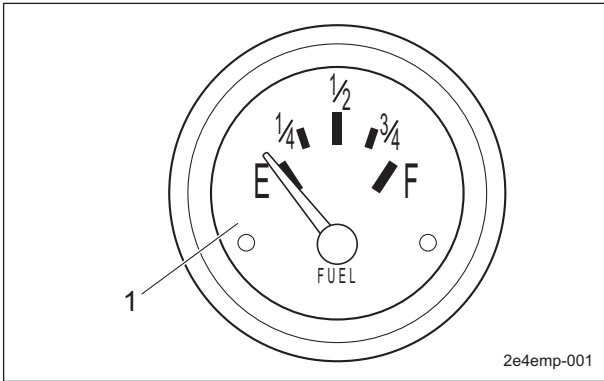

Fuel Supply_001

1	Fuel gauge
---	------------

Air Bleeding of Fuel System

Important

The air-bleed cock should normally be in the fully open position.

Using the machine with the air-bleed cock in the closed position may cause the engine to stall.

Air bleeding is not a required operation since it occurs automatically.

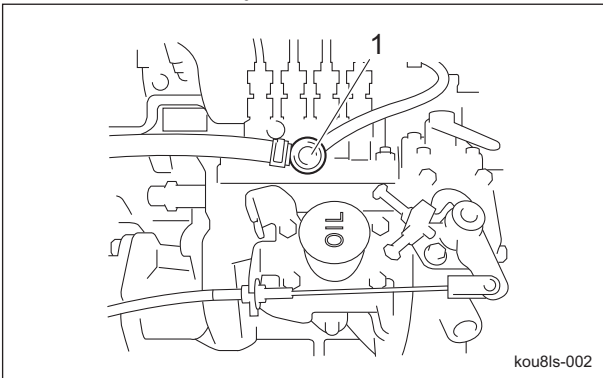

Air Bleeding of Fuel System_001

1	Air-bleed cock
---	----------------

Oil Leakage

Inspection of Oil Leakage

Caution

When performing maintenance on the hydraulic system, lower the cutting units.

After approximately 50 hours of operation, some joints may be loosened and oil may leak. Check the bottom of the machine for oil leakage.

Tightening torques

Standard tightening torques

Bolts and screws

Unless otherwise instructed, tighten bolts or nuts by the specified torque using an appropriate tool. Excessive tightening of a screw may cause it to become loose or damaged. The appropriate tightening torque depends on factors such as the type of screw, its strength, and the friction of its thread and bearing surface.

The following list is for galvanized and parkerized bolts only. The values given in this list do not apply to low-strength female screws.



Do not use a screw that has rusted or has foreign matter such as sand on it. Such a screw cannot be fully tightened even if it is tightened by the specified torque. The friction on the thread surface increases, causing a loss of torque that results in an insufficient tightening torque being exerted. If a screw is wet or oily, do not tighten it by the specified torque. If a screw gets wet, the torque coefficient decreases, resulting in excessive tightening of the screw if it is tightened by the specified torque.

Excessive tightening of a screw may cause it to elongate, resulting in the screw becoming loose or damaged. Do not use a screw that has already been subjected to a large load.

Tightening a bolt with an impact wrench requires skill. Practice tightening bolts to ensure you are able to tighten them reliably.

Nominal diameter	General bolts		
	Strength class: 4.8		
			
	N-m	kgf-cm	lb-in
M5	3 - 5	30.59 - 50.99	26.55 - 44.26
M6	7 - 9	71.38 - 91.77	61.96 - 79.66
M8	14 - 19	142.76 - 193.74	123.91 - 168.17
M10	29 - 38	295.71 - 387.49	256.68 - 336.34
M12	52 - 67	530.24 - 683.20	460.25 - 593.02
M14	70 - 94	713.79 - 958.52	619.57 - 831.99
M16	88 - 112	897.34 - 1142.06	778.89 - 991.31
M18	116 - 144	1,182.85 - 1,468.37	1,026.72 - 1,274.54
M20	147 - 183	1,498.96 - 1,866.05	1,301.10 - 1,619.73
M22	295	3,008.12	2,611.05
M24	370	3,772.89	3,274.87
M27	550	5,608.35	4,868.05
M30	740	7,545.78	6,549.74

Handling Instructions

Nominal diameter	Heat-treated screws					
	Strength category: 8.8			Strength category: 10.9		
						
	N-m	kgf-cm	lb-in	N-m	kgf-cm	lb-in
M5	5 - 7	50.99 - 71.38	44.26 - 61.96	7 - 10	71.38 - 101.97	61.96 - 88.51
M6	8 - 11	81.58 - 112.17	70.81 - 97.36	14 - 18	142.76 - 183.55	123.91 - 159.32
M8	23 - 29	234.53 - 295.71	203.57 - 256.68	28 - 38	285.52 - 387.49	247.83 - 336.34
M10	45 - 57	458.87 - 581.23	398.30 - 504.51	58 - 76	591.43 - 774.97	513.36 - 672.68
M12	67 - 85	683.20 - 866.75	593.02 - 752.34	104 - 134	1,060.49 - 1,366.40	920.50 - 1186.03
M14	106 - 134	1,080.88 - 1,366.40	938.21 - 1,186.03	140 - 188	1,427.58 - 1,917.04	1,239.14 - 1,663.99
M16	152 - 188	1,549.94 - 1,917.04	1,345.35 - 1,663.99	210 - 260	2,141.37 - 2,651.22	1,858.71 - 2,301.26
M18	200 - 240	2,039.40 - 2,447.28	1,770.20 - 2,124.24	280 - 340	2,855.16 - 3,466.98	2,478.28 - 3,009.34
M20	245 - 295	2,498.27 - 3,008.12	2,168.50 - 2,611.05	370 - 450	3,772.89 - 4,588.65	3,274.87 - 3,982.95
M22	-	-	-	530	5,404.41	4,691.03
M24	-	-	-	670	6,831.99	5,930.17
M27	-	-	-	1,000	10,197.00	8,851.00
M30	-	-	-	1,340	14,628.78	11,860.34

Note:

The above values also apply for fine screw threads.

Principal tightening torques

Tightening Torque by Model

GM2800B

Tighten the following bolts and nuts at the torque specified in the table.

For thread locking adhesive, apply a middle strength thread locker (ThreeBond 1322 anaerobic adhesives).

Portion	Code	Part name	Tightening torque			Thread locking adhesive	
			N-m	kgf-cm	lb-in		
Front wheel	Motor housing	K0014160402	Bolt, 11T, heat-treated M16-40P1.5	152 - 188	1549.94 - 1917.04	1345.35 - 1663.99	—
	Motor	K0013140502	Bolt, heat-treated M14-50	100	1019.7	885.1	—
	Wheel mounting base	1 1/4-18UNF	With hydraulic motor: Slotted nut	200	2039.40	1770.20	—
	Disc brake	K0024080401	Bolt, w/hexagon hole, M8-40	28 - 38	285.52 - 387.49	247.83 - 336.34	—
	Wheel	K0014120652	Bolt, heat-treated M12-65P1.5	67 - 85	683.20 - 833.75	593.02 - 752.34	—
Rear wheel	Motor	K0010120502	Bolt, 11T, heat-treated M12-50	52 - 67	530.42 - 683.20	460.25 - 593.02	—
	Wheel mounting base	K0138240002	24 slotted nut high P1.5	180 - 200	1835.46 - 2039.40	1593.18 - 1770.20	—

Handling Instructions

Portion		Code	Part name	Tightening torque			Thread locking adhesive
				N-m	kgf-cm	lb-in	
Rear wheel	Wheel	K0014120652	Bolt, heat-treated M12-65P1.5	67 - 85	683.20 - 866.75	593.02 - 752.34	—
Front axle		K00152200702	Bolt, heat-treated M20-70P1.5	370 - 450	3772.89 - 4588.65	3274.87 - 3982.95	—
Brake ass'y		K1720000190	Bolt, heat-treated M12P1.75	150 ± 15	1529.55 ± 152.96	1327.65 ± 132.77	○
Engine		K0012120352	Bolt, heat-treated M12-35P1.25	67 - 134	683.20 - 1366.40	593.02 - 1186.03	—
		K0012120552	Bolt, heat-treated M12-55P1.25	67 - 134	683.20 - 1366.40	593.02 - 1186.03	—
		K0011100502	Bolt, heat-treated M10-50P1.25	45 - 76	458.87 - 774.97	398.30 - 672.68	—
		K0013121102	Bolt, heat-treated M12-110	67 - 134	683.20 - 1366.40	593.02 - 1186.03	○
Flywheel adapter		K0010140302	Bolt, heat-treated M14-30	108 - 188	1101.28 - 1917.04	1663.99 - 1663.99	—
		K0011100202	Bolt, heat-treated M10-20P1.25	45 - 76	458.87 - 774.97	398.30 - 672.68	○
Joint		K0024100401	Bolt, 12T, w/hexagon hole, M10-40	80	815.76	708.08	○
		K0013100352	Bolt, 11T, heat-treated M12-55	52 - 67	530.24 - 683.20	460.25 - 593.02	—
Kingpin stopper		K0013120552	Bolt, 11T, heat-treated M12-45	52 - 67	530.24 - 683.20	460.25 - 593.02	—
Tie rod		K1610000020	Tie rod end slotted nut	45	458.87	398.30	—
		K1611000020	Tie rod end slotted nut	45	458.87	398.30	—
Piston pump		K0013120502	Bolt, heat-treated M12-50	67 - 134	683.20 - 1366.40	593.02 - 1186.03	—
Tandem pump	Accessories		3/8-24 UNC 11T 10	29 - 38	295.71 - 387.49	256.68 - 336.34	—
Rotary mower bracket		K0011100302	Bolt, heat-treated M10-30P1.25	29 - 38	295.71 - 387.49	256.68 - 336.34	—
Pedal stopper		K0013101202	Bolt, heat-treated M10-120	29 - 38	295.71 - 387.49	256.68 - 336.34	—
Rotation sensor		K0015120351	Bolt, heat-treated M12-35P1.25	67 - 134	683.20 - 1366.40	593.02 - 1186.03	—
Diff-lock valve		K0024100151	Bolt, w/hexagon hole, M10-15	29 - 38	295.71 - 387.49	256.68 - 336.34	—
Knife guide		K0010120302	Bolt, heat-treated M12-30	67 - 85	683.20 - 866.75	593.02 - 752.34	—
Step bolt		GM2800-0207Z2	Step bolt	52 - 67	530.24 - 683.20	460.25 - 593.02	—
Arm guide		K00131010002	Bolt, heat-treated M10-100	45 - 76	458.87 - 774.97	398.30 - 672.68	—

Handling Instructions

Portion	Code	Part name	Tightening torque			Thread locking adhesive
			N-m	kgf-cm	lb-in	
Bumper	K0010120302	Bolt, heat-treated M12-30	67 - 134	683.20 - 1366.40	593.02 - 1186.03	—
Cover mounting bracket	K0000080202	Bolt, M8-25	9 - 14	91.77 - 142.76	61.96 - 123.91	—
Valve V5267	K0013080902	Bolt, 11T, heat-treated M10-90	14 - 19	142.76 - 193.74	123.91 - 168.17	
Solenoid valve V5266	K0013101202	Bolt, 11T, heat-treated M10-90	29 - 38	295.71 - 387.49	256.68 - 336.34	

Adjustment Before Operating

Adjustment of Steering Wheel

Warning

Since it is dangerous, do not adjust the steering wheel while traveling.

Caution

Be sure the steering wheel position is securely locked. It would be extremely dangerous if it becomes loose while traveling.

The steering wheel can be adjusted up or down. Adjust the position according to the operator's body size.

Shift the tilt lever to the "FREE" position, move the steering wheel to the position that suits your work requirements, and then shift the tilt lever to the "LOCK" position to secure the steering wheel in place.

The tilt lever is located in the right front of the driver's position.

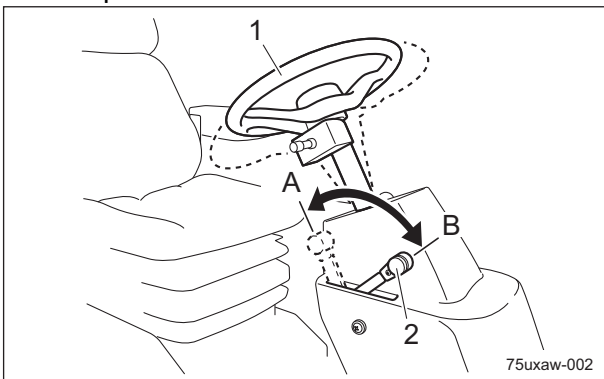

Adjustment of Steering Wheel_001

1	Steering wheel
2	Tilt lever
A	FREE (released)
B	LOCK (locked)

Adjustment of Seat

Use the seat adjustment levers to adjust the seat.

Adjust the position according to the operator's body size.

1. Use the forward/backward adjustment lever to adjust the seat back and forth.
2. Use the backrest tilt adjustment lever to adjust the angle of the backrest.
3. Turn the suspension adjustment handle to adjust the firmness of the seat suspension. Observe the suspension adjustment scale while making adjustments. (50 - 130 kg)
4. Turn the armrest adjustment knob to adjust the angle of the armrests.

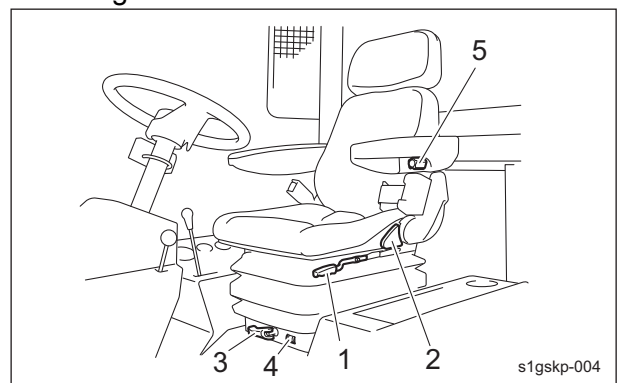

Adjustment of Seat_001

1	Forward/backward adjustment lever
2	Backrest tilt adjustment lever
3	Suspension adjustment handle
4	Suspension adjustment scale
5	Armrest adjustment knob

Handling Instructions

5. Lift the seat to adjust its height to one of three positions.

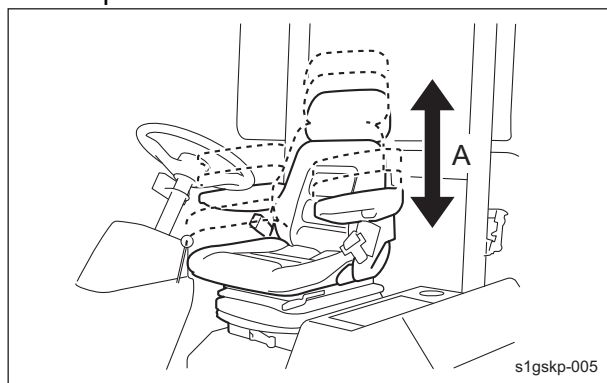

Adjustment of Seat_002

A	Three positions
---	-----------------

Adjustment of Cutting Height

Cutting Height Table

The adjustment range for the cutting height is 20.0 - 91.5 mm.

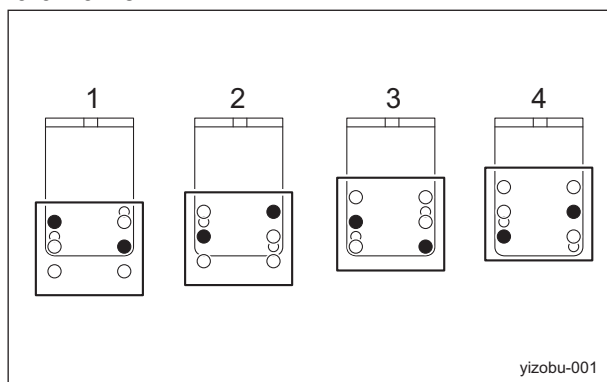

Cutting Height Table_001

1	Adjusting plate position 1
2	Adjusting plate position 2
3	Adjusting plate position 3
4	Adjusting plate position 4

Adjusting Plate Position	1	2	3	4
Adjusting Collars (Number)	Cutting Height (mm)			
0	20.0	30.0	45.5	55.5
1	26.0	36.0	51.5	61.5
2	32.0	42.0	57.5	67.5
3	38.0	48.0	63.5	73.5
4	44.0	54.0	69.5	79.5
5	50.0	60.0	75.5	85.5
6	56.0	66.0	81.5	91.5

Note:

The factory default cutting height is 48 mm.

Adjustment With Adjusting Collars

Adjusting collars are installed at three locations on each mower unit.

Important

The length of grass cut off at any one time must be no more than 30 mm.

Important

Do not cut off more than 1/3 of the grass height.

1. Apply the parking brake, and then lower all mower units.
2. Stop the engine, and then remove the key.
3. Loosen the nuts securing the adjusting collars at the three locations.

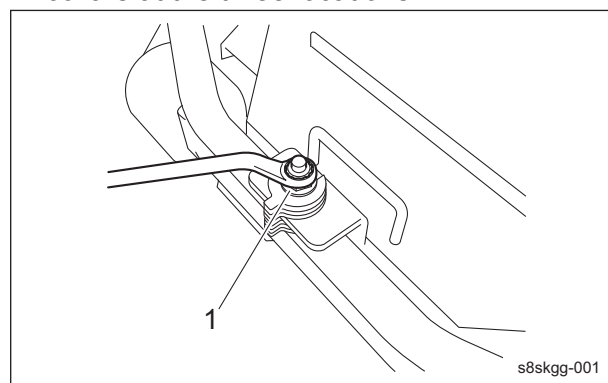

Adjustment With Adjusting Collars_001

1	Nut
---	-----

4. Refer to the Cutting Height Table, and then adjust the number of adjusting collars at the three locations.

[1] To increase cutting height:

Remove an upper adjusting collar and insert it below.

Handling Instructions

[2] To decrease cutting height:
Remove a lower adjusting collar and insert it above.

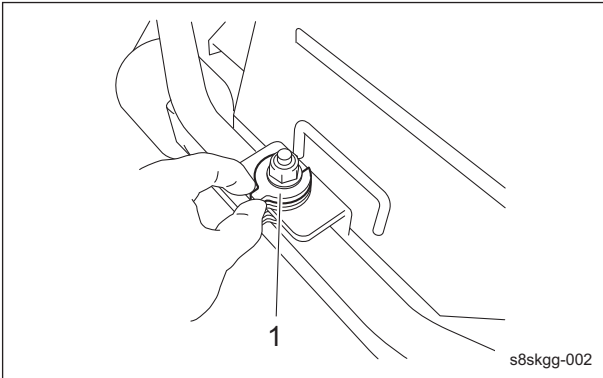

Adjustment With Adjusting Collars_002

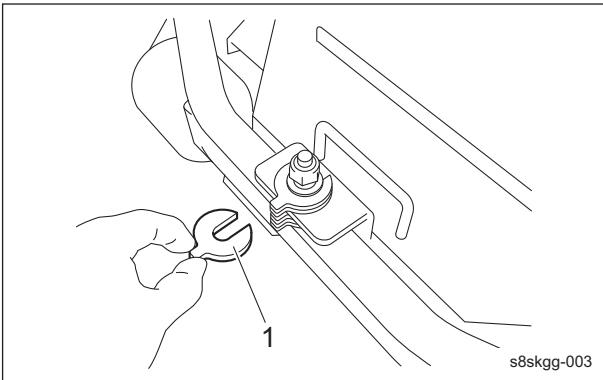

Adjustment With Adjusting Collars_003

1	Adjusting collar
---	------------------

5. After adjusting the adjusting collars at the three locations, firmly tighten all nuts.

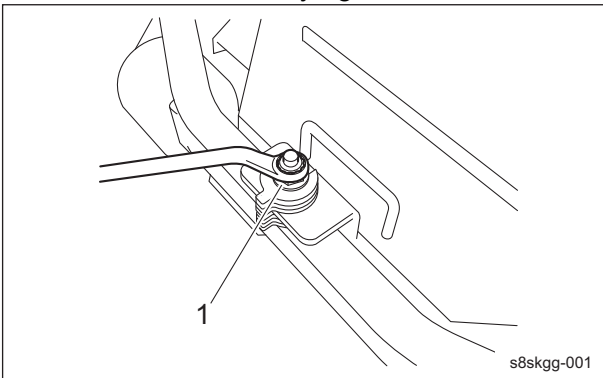

Adjustment With Adjusting Collars_004

1	Nut
---	-----

Adjustment With Cutting Height Adjusting Plates

Cutting height adjusting plates are installed at three locations on each mower unit.

Important

The length of grass cut off at any one time must be no more than 30 mm.

Important

Do not cut off more than 1/3 of the grass height.

1. Apply the parking brake, and then lower all mower units.
2. Stop the engine, and then remove the key.
3. Loosen the six bolts securing the cutting height adjusting plates at the three locations on the mower unit.

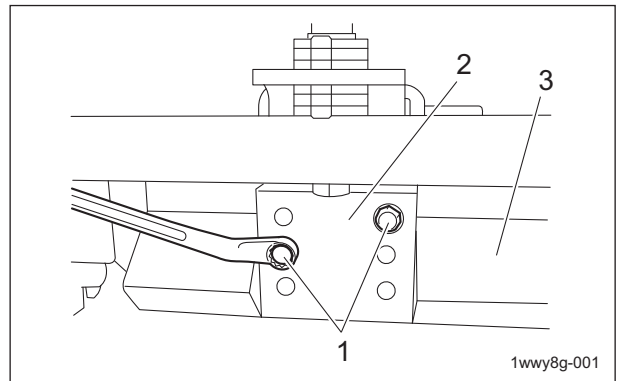

Adjustment With Cutting Height Adjusting Plates_001

1	Bolt
2	Mower unit
3	Cutting height adjusting plate

4. Refer to the Cutting Height Table, and then change the hole positions.

[1] To increase cutting height:

- a. While lifting the handle at each location on the mower unit, remove the two bolts.
- b. Raise the mower unit to change the hole positions, and then temporarily secure it with the two bolts.

[2] To decrease cutting height:

- a. While lifting the handle at each location on the mower unit, remove the two bolts.

Handling Instructions

b. Lower the mower unit to change the hole positions, and then temporarily secure it with the two bolts.

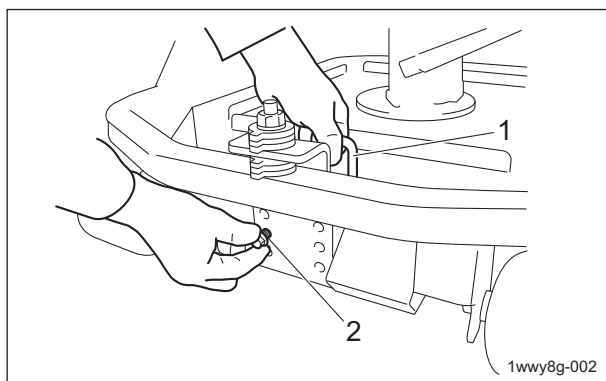

Adjustment With Cutting Height Adjusting Plates_002

1	Handle
2	Bolt

5. After making adjustments at the three locations, firmly tighten all bolts.

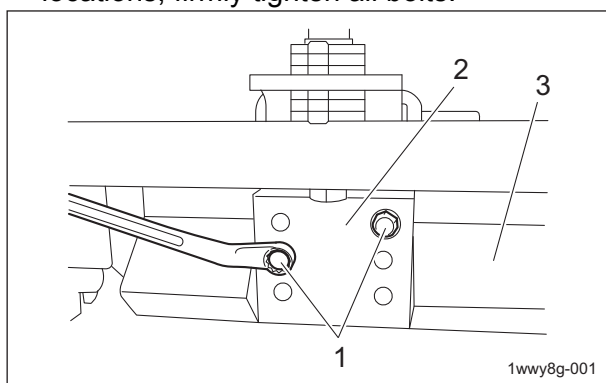

Adjustment With Cutting Height Adjusting Plates_003

1	Bolt
2	Mower unit
3	Cutting height adjusting plate

Procedure to Start / Stop Engine

Start / Stop of Engine

Procedure to Start Engine



Warning
Before starting the engine, make sure that there are no other people or obstacles around the machine.

Important

Starter operation must take 15 seconds or less.
If the engine does not start, stop using the battery for 30 to 60 seconds to avoid exhausting the battery.

1. Sit on the seat.
2. Make sure that the parking brake is applied.
3. Make sure that the knife rotation switch is in the "OFF" position.
4. Make sure that the traveling pedal is in the neutral position.
5. Shift the throttle lever from the turtle icon (low speed) halfway to the rabbit icon (high speed).

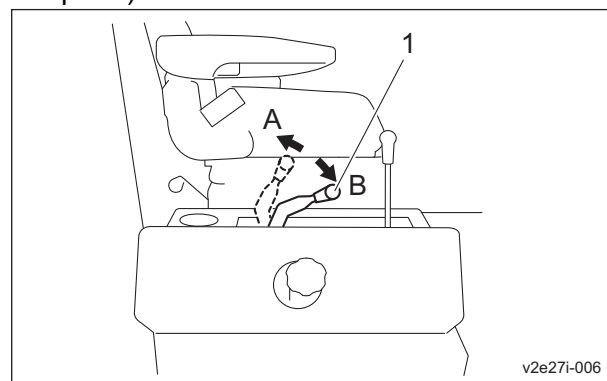

Procedure to Start Engine_001

1	Throttle lever
A	High
B	Low

Important

The thermo-start lamp turns off at the specified time. However, the lamp turning off is not related to the glow plug generating heat.
If the ignition key is left in the "GLOW" position after the lamp is turned off, the plug will still generate heat.
The lamp will stay illuminated for five seconds.

6. Switch the ignition key to the "GLOW" position.

Handling Instructions

7. Make sure that the glow plug is generating heat and the thermo-start lamp is turned on.

⚠ Caution

Quickly returning the ignition key from the "START" position to the "ON" position may result in damage to the machine.

8. After the thermo-start lamp turns off, immediately set the ignition key to the "START" position.
9. When the starter starts rotating and the engine starts, slowly return the ignition key to the "ON" position.

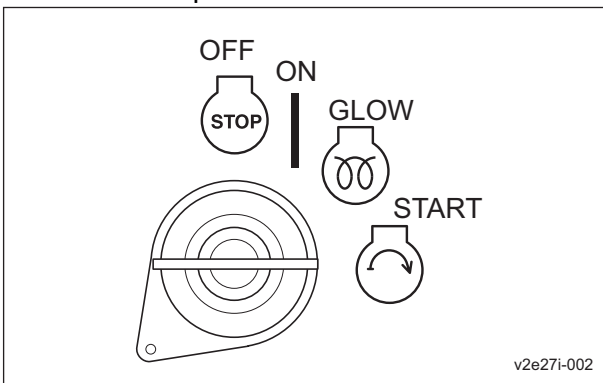

Procedure to Start Engine_002

10. Make sure that the charge lamp and engine oil pressure lamp turn off. If they do not turn off, stop the engine and inspect the machine.

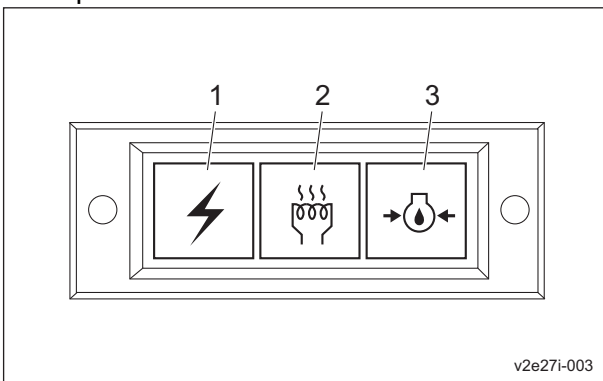

Procedure to Start Engine_003

1	Charge lamp
2	Thermo-start lamp
3	Oil pressure lamp

11. Shift the throttle lever to the turtle icon (low speed), and then warm up the engine for 1-2 minutes.
12. Gradually move the throttle lever to the rabbit icon (high speed).

Procedure to Stop Engine

1. Set the traveling pedal to the neutral position.
2. Apply the parking brake.
3. Set the knife rotation switch to the "OFF" position.
4. Shift the throttle lever to the turtle icon (low speed), and then idle the machine for 1-2 minutes.
5. Switch the ignition key to the "OFF" position.
6. Make sure that the engine has stopped.
7. Remove the ignition key.
8. Leave the driver's seat.

Safety Mechanisms

This machine features a safety device for starting/stopping the engine.

1. As for starting the engine, the safety device prevents the engine from starting unless it meets each of the following four conditions.
 - An operator is sitting on the seat.
 - The parking brake is applied.
 - The knife rotation switch is set to the "OFF" position.
 - The traveling pedal is set to the neutral position.
2. In the event the operator leaves the seat with the parking brake applied and the engine running, the safety device will be activated and will stop the engine under any of the following conditions:
 - The traveling pedal is not set to the neutral position. (The operator has depressed the traveling pedal.)
 - The knife rotation switch is set to the "ON" position.

Warning Mechanisms

This machine features warning mechanisms for overheating and for the hydraulic oil.

1. If the engine water temperature exceeds 115 degrees Celsius, a buzzer will sound. (intermittent tone)
2. If the oil level in the hydraulic tank decreases to 2.0 dm³ (2.0 L), a buzzer will sound. (continuous tone)

Handling Instructions

Operation of Each Section

Precautions for Operating the Machine

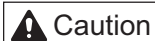

Drive the machine at such a speed that you can stop it immediately for emergencies.

Cautions for when You Leave the Machine



If the brake feels soft or ineffective, use the wheel stoppers to secure the machine.

Instruction Decals

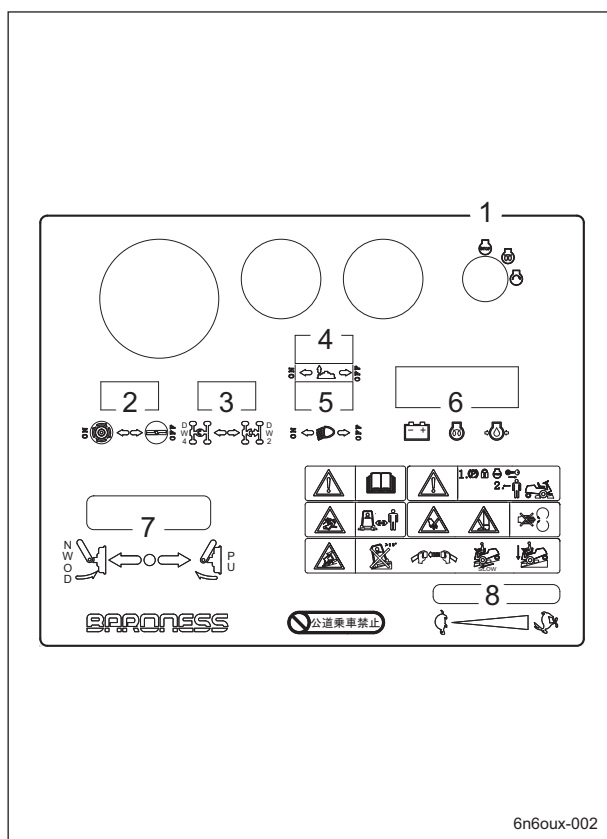

Instruction Decals_001

1	Ignition key
2	Knife rotation switch
3	2WD/4WD selector switch
4	Traction assist switch
5	Headlight switch
6	Pilot lamps
7	Mower unit up/down lever
8	Throttle lever

Proximity Sensors

There are two proximity sensors on mower arm fulcrums #4 and #5.

These sensors detect the raised or lowered positions of mower units #4 and #5 and rotate or stop the rotary knives.

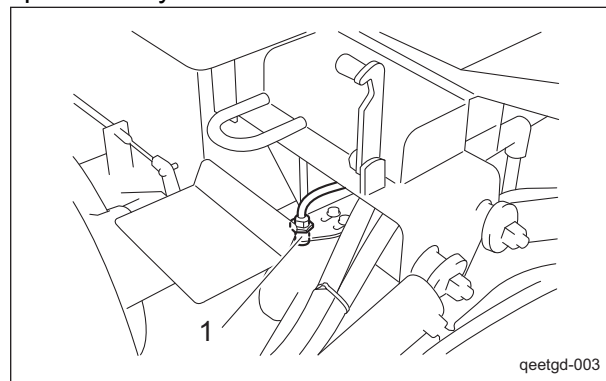

Proximity Sensor_001

1	Proximity sensor
---	------------------

Relays

The relay box is at the front of the right hood. These relays control operation of the diff-lock valve, rotation of the rotary knives, 2WD/4WD selection and traction assist selection. The operating condition can be checked by the illumination of the LEDs.

- LEDs ①, ② and ③ light up when the diff-lock valve is in the "ON" position.
- LED ④ lights up when the traction assist switch is in the "ON" position.
- LEDs ⑤ and ⑥ light up when the knife rotation switch is in the "ON" position and the mower deck is lowered.
- LED ⑦ lights up when the knife rotation switch is in the "ON" position, and then the machine enters 4WD.

Handling Instructions

- LED ⑧ lights up when the 2WD/4WD selector switch is in the "4WD" position, and then the machine enters 4WD.

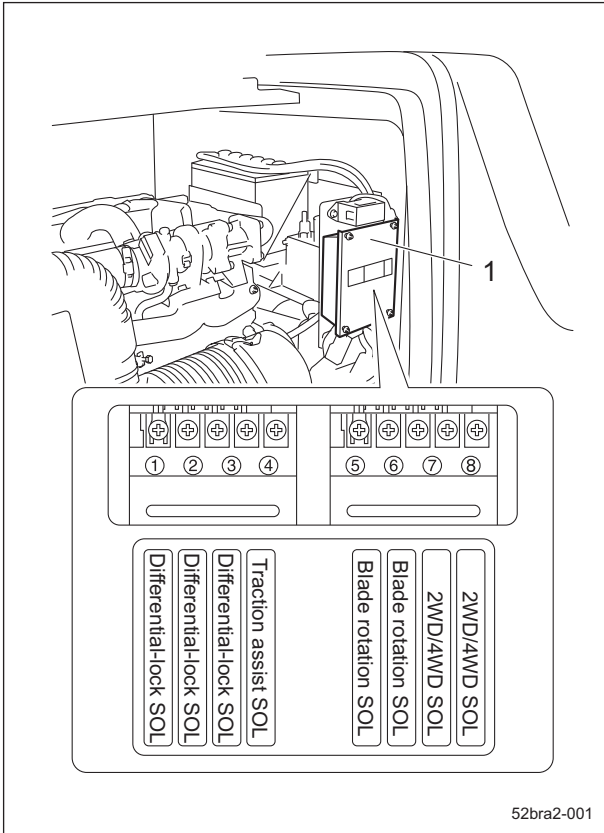

Relays_001

1	Relay box
---	-----------

The knife rotation switch is located in the operation panel and controls the rotation of the rotary knives.

When the knife rotation switch is set to the "ON" position, the rotary knife in all mower units rotates. When the knife rotation switch is set to the "OFF" position, the rotary knives stop. When the mower units are raised, the rotary knives do not rotate, even if the switch is set to the "ON" position.

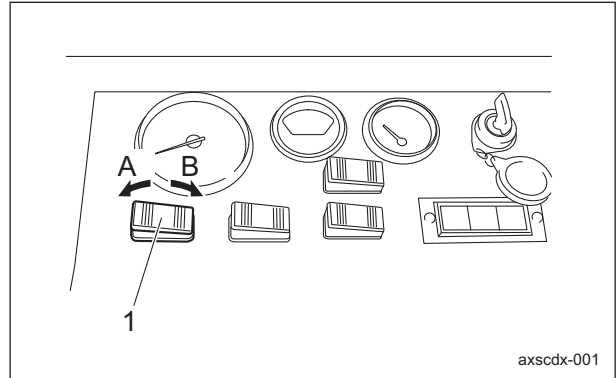

Knife Rotation Switch_001

1	Knife rotation switch
A	ON
B	OFF

Note:

When the knife rotation switch is set to the "ON" position, the machine enters 4WD, regardless of the position that the 2WD/4WD selector switch is set to.

Knife Rotation Switch

Caution

Before you start cutting work, set the knife rotation switch to the "ON" position. At all other times, make sure it is set to the "OFF" position.

2WD/4WD Selector Switch

Caution

When working on a slope, be sure to use the machine in 4WD.

Caution

When traveling, be sure to stop the knives and raise the mower units.

Handling Instructions

The 2WD/4WD selector switch is located in the operation panel.

When the switch is set to the "2WD" position, the machine will be in two-wheel drive (front-wheel drive). When it is set to the "4WD" position, the machine will be in four-wheel drive.

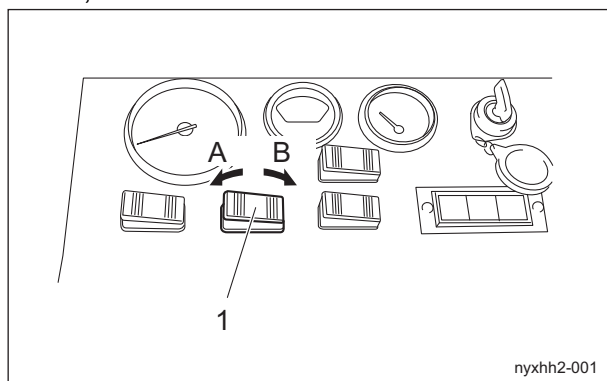

2WD/4WD Selector Switch_001

1	2WD/4WD selector switch
A	4WD
B	2WD

Note:

When the knife rotation switch is set to the "ON" position, the machine enters 4WD, regardless of the position that the 2WD/4WD selector switch is set to.

Light Switch



Warning

The lights provide auxiliary lighting. Do not travel or operate the machine at night or under poor visibility.

The light switch is located in the operation panel. When the switch is set to the "ON" position, the lights turn on. When it is set to the "OFF" position, the lights turn off.

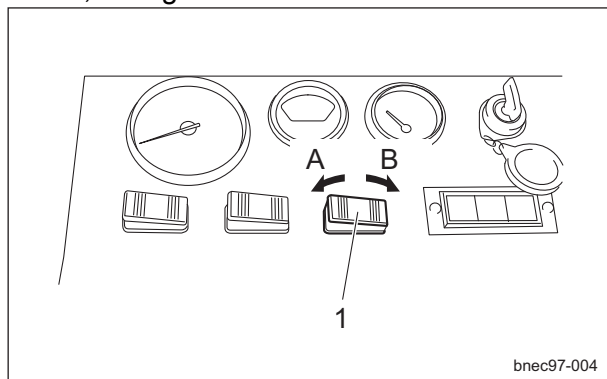

Light Switch_001

1	Light switch
A	ON
B	OFF

Traction Assist Switch

The traction assist switch is located in the operation panel.

When the switch is set to the "ON" position, the mower units are floating, increasing their efficiency on an ascending slope.

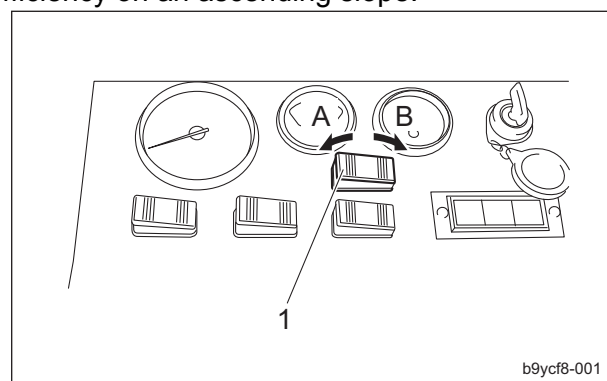

Traction Assist Switch_001

1	Traction assist switch
A	ON
B	OFF

Note:

Tracking may be impaired if the machine is used with the switch set to the "ON" position in an area with many undulations.

Mower Lock Lever (Latch)

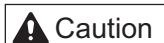

Caution

When the mower lock levers (latches) are engaged, do not operate the mower unit up/down lever.

Handling Instructions

The mower lock levers (latches) are located in the foot area on the left and right sides and are used when storing the machine with mower units #4 and #5 raised.

When storing the machine, hook the mower lock levers (latches) on the arms.

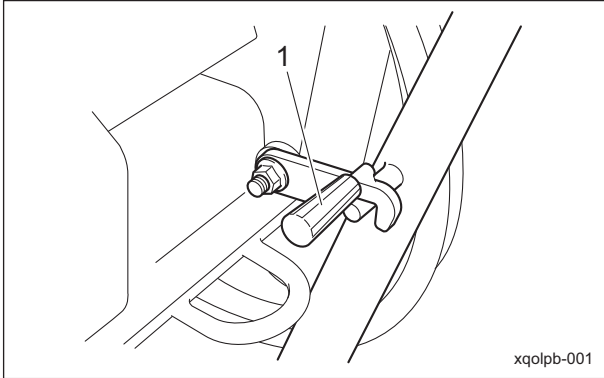

Mower Lock Lever (Latch)_001

1	Mower lock lever (latch)
---	--------------------------

Mower Unit Up/Down Lever

⚠ Caution

Before operating the mower unit up/down lever, make sure that the mower lock levers (latches) are not engaged.

⚠ Caution

Before raising or lowering the mower units, make sure that there are no people around the machine.

The mower unit up/down lever is located on the right side of the driver's seat and raises or lowers the mower units.

When the lever is shifted to the "DOWN" position, the mower units are lowered. When the lever is shifted to the "UP" position, the mower units are raised.

Release the lever to return it to the neutral position.

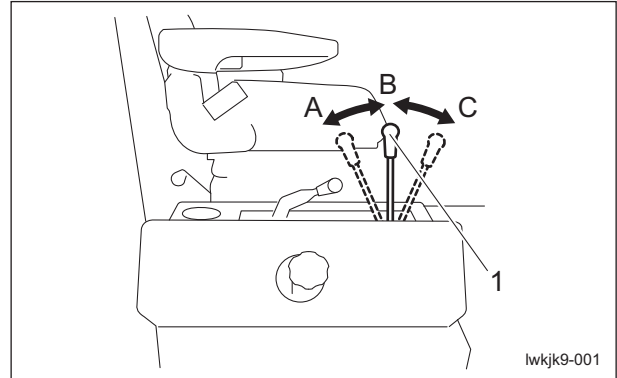

Mower Unit Up/Down Lever_001

1	Mower unit up/down lever
A	UP
B	Neutral
C	DOWN

Note:

When the mower units are raised, the knives stop rotating, even if the knife rotation switch is set to the "ON" position.

Throttle Lever

The throttle lever is located to the right of the driver's seat and enables you to adjust the engine rpm.

Move the throttle lever toward the rabbit icon (high speed) to increase the engine rpm, and toward the turtle icon (low speed) to reduce the rpm.

Handling Instructions

Note:
The factory default engine rpm (maximum) is set to 2,600 rpm.

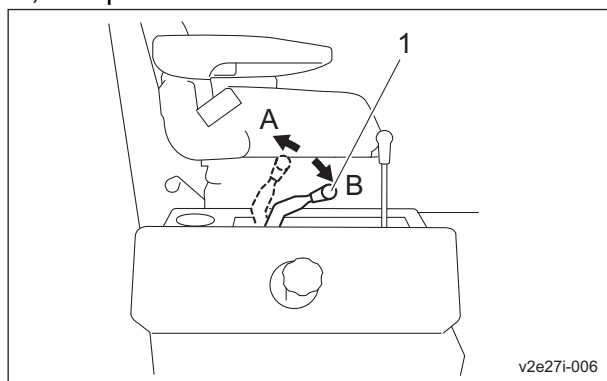

Throttle Lever_001

1	Throttle lever
A	Rabbit icon (high speed)
B	Turtle icon (low speed)

Diff-Lock Switch

Caution

Do not operate the diff-lock switch unless it is necessary. It may result in the hydraulic system malfunction.

The diff-lock switch is located below the right side of the steering wheel and engages the differential lock for the left and right front wheels. Tilt the switch lever up or down to turn "ON" to engage the differential lock for the front wheels. Release the switch lever to return it to the neutral position ("OFF" position) and disengage the differential lock.

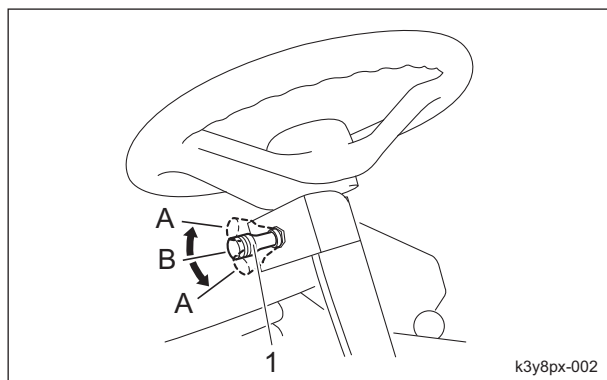

Diff-Lock Switch_001

1	Diff-lock switch
A	ON
B	OFF

Traveling Pedal

Warning

This machine is not authorized as a special motor vehicle. Do not drive it on public roads.

Caution

When the machine is traveling at a high speed, it will not stop immediately after you take your foot off the traveling pedal. If necessary, also use the brake.

The traveling pedals are located in the right foot area and control forward and reverse operation of the machine.

When the forward pedal (inside) is depressed, the machine travels forward. When the reverse pedal (outside) is depressed, the machine travels in reverse.

The speed changes in accordance with how much the pedal is depressed.

When you take your foot off the pedal, the machine stops automatically.

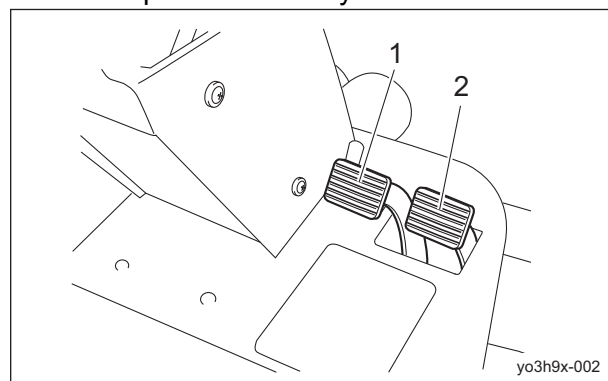

Traveling Pedal_001

1	Forward pedal
2	Reverse pedal

Brake Pedal

Warning

Link the brake pedals, except when operating the machine. Using the brake pedals without linking them may result in the machine overturning.

Handling Instructions

Warning

When depressing the brake pedals to make turns with a small radius, obtain a sufficient awareness of the lawn and ground conditions.
This may damage the lawn.

The brake pedals are located in the left foot area and operate the left and right brakes independently.

By depressing the brake pedal on the side in which the turn will be made, the machine can make turns with a small radius.

If the front wheel on the upward side of a slope slips, depress the brake pedal for the wheel on the upward side in order to increase the traction of the wheel on the downward side and stabilize travel.

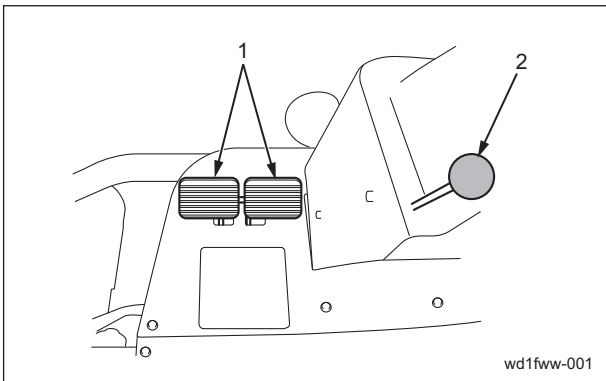

Brake Pedal_001

1	Brake pedals
2	Parking brake lever

Change of Braking Method

Follow the procedure below to change the braking method from linked to independent.

1. Swing up the pedal link bar, and then pull it out from the right brake pedal.

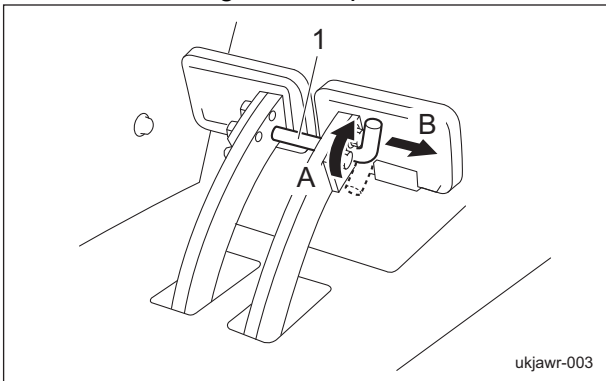

Change of Braking Method_001

1	Pedal link bar
A	Swing up
B	Pull out

2. Secure the pedal link bar in the holder on the left brake pedal.

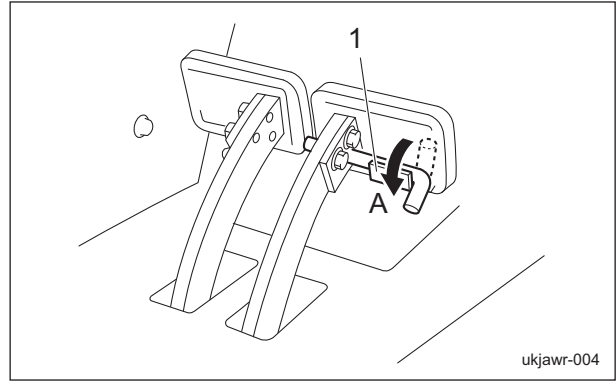

Change of Braking Method_002

1	Holder
A	Secure

Parking Brake Lever

Caution

Be sure to release the parking brake before driving.
It may result in the brakes or hydraulic system malfunction.

Caution

Never park the machine on a slope.

The parking brake lever is located to the left of the front cover.

When parking, link the left and right brake pedals by using the pedal link bar, depress both brake pedals, and then pull the parking brake lever completely.

To release the parking brake, depress the brake pedals.

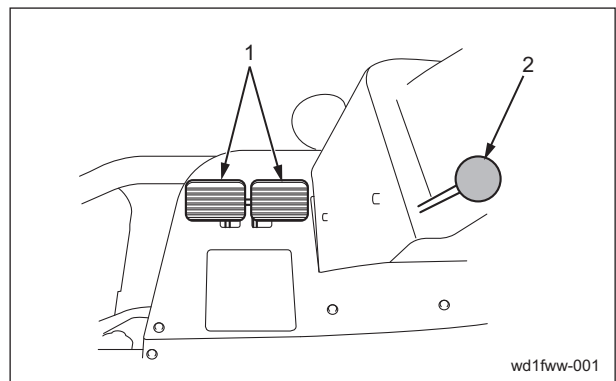

Parking Brake Lever_001

Handling Instructions

1	Brake pedals
2	Parking brake lever

Hood



Do not open the hood in strong winds.



Be careful not to pinch your fingers when you open or close the hood.

1. Unlock the rubber catch, and then lift up the hood.
2. Hook the hood support rod onto the latch inside the hood.
Make sure that the hood will not close, and then remove your hands.

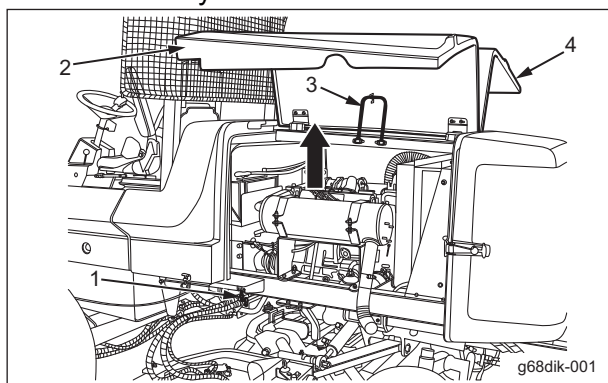

Hood_001

1	Rubber catch
2	Left hood
3	Hood support rod
4	Right hood

3. To close the hood, release the hood support rod from the latch, and then lower the hood slowly.
4. Lock the rubber catch securely.

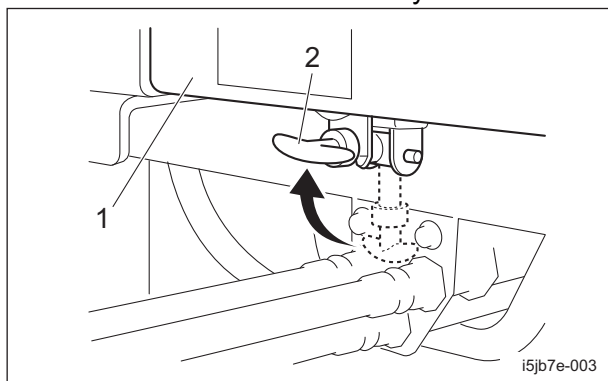

Hood_002

1	Hood
2	Rubber catch

Underseat Cover



Be careful not to pinch your fingers when you open or close the underseat cover.

1. Make sure that the steering wheel is raised completely.
2. Bring the seat to the backmost position.
3. Pull up the lever behind the seat to unlock it.

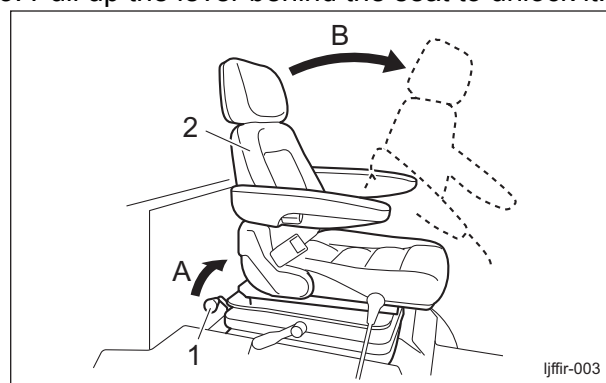

Underseat Cover_001

1	Lever
2	Seat
A	Pull up
B	Tilt forward

4. Tilt the seat forward to open the cover.
To close the cover, slowly lower the seat.

Instruments

Instruments on the Operation Panel

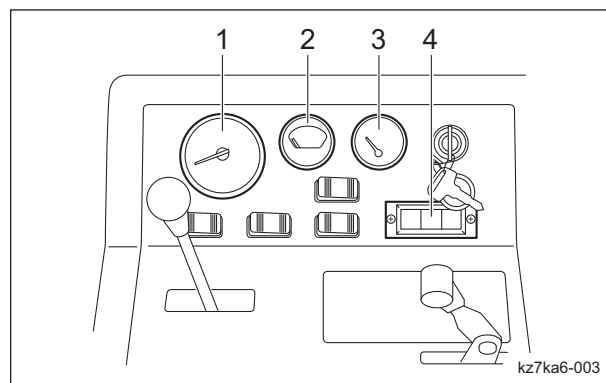

Instruments on the Operation Panel_001

Handling Instructions

1	Tachometer/Hour meter
2	Water temperature gauge
3	Fuel gauge
4	Pilot lamps (charge lamp, thermo-start lamp, oil pressure lamp)

Tachometer/Hour Meter

The tachometer and hour meter are located in the operation panel.
 The tachometer indicates the engine rpm. It is connected to a rotation sensor in the engine flywheel area, and converts the signal output from the rotation sensor into an rpm value. The hour meter indicates total operation time of the engine. Every six minutes of engine operation will increase the number at the first digit (black number on a white background) by one. Every one hour of engine operation will increase the number at the next digit (white number on a black background) by one.

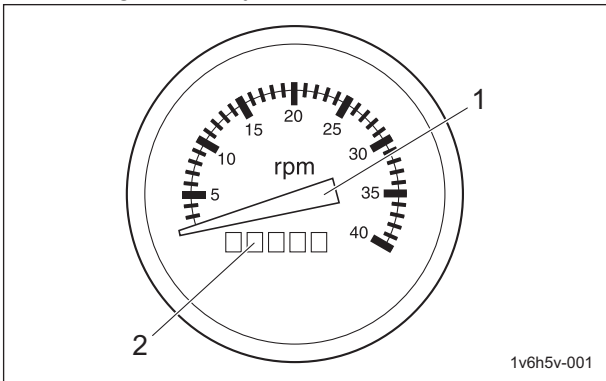

Tachometer/Hour Meter_001

1	Tachometer
2	Hour meter

Water Temperature Gauge

The water temperature gauge is located in the operation panel. This instrument indicates the water temperature inside the engine. If the water temperature gauge indicates a level close to "H" during operation, the machine is overheated.

Remove the load from the engine, idle the machine for five minutes, stop the engine, and then inspect the machine and perform any necessary maintenance. If the water temperature exceeds 115 degrees Celsius, a buzzer will sound. (intermittent tone)

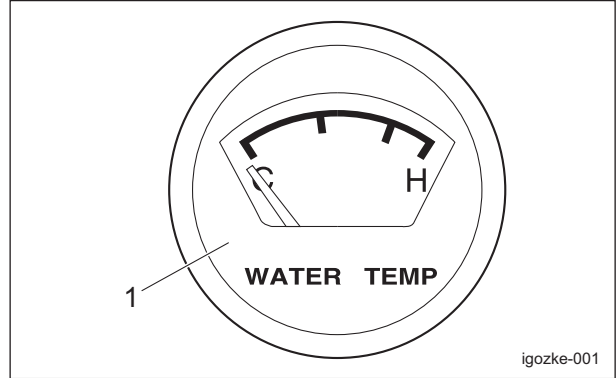

Water Temperature Gauge_001

1	Water temperature gauge
---	-------------------------

Fuel Gauge

The fuel gauge is located in the operation panel. This instrument indicates the quantity of fuel inside the fuel tank.

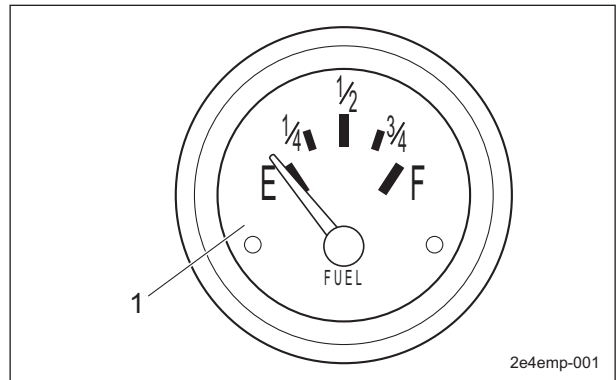

Fuel Gauge_001

1	Fuel gauge
---	------------

Handling Instructions

Pilot Lamps

Charge Lamp

The charge lamp is the left pilot lamp located in the operation panel.

It turns on when the ignition key is set to the "ON" position before the engine starts. It turns off when the engine starts and the alternator starts operating properly.

If this lamp illuminates while you are operating the machine, stop the engine immediately, and then inspect the machine and perform any necessary maintenance.

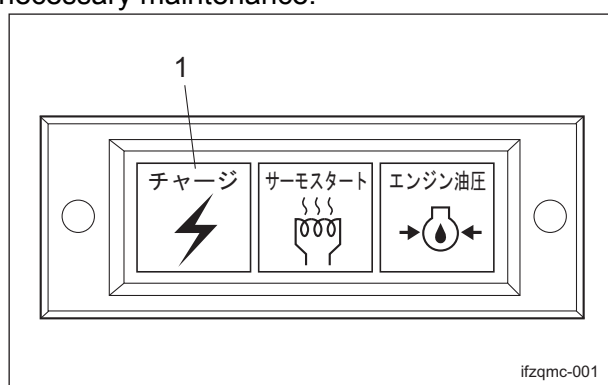

Charge Lamp_001

1	Charge lamp
---	-------------

Oil Pressure Lamp

The oil pressure lamp is the right pilot lamp located in the operation panel.

It turns on when the ignition key is set to the "ON" position before the engine starts. It turns off when the engine starts and engine oil pressure is generated properly.

If this lamp illuminates while you are operating the machine, stop the engine immediately, and then inspect the machine and perform any necessary maintenance.

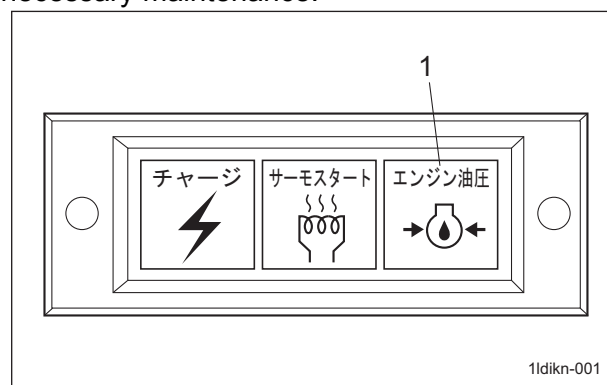

Oil Pressure Lamp_001

1	Oil pressure lamp
---	-------------------

Thermo-start Lamp

The thermo-start lamp is the middle pilot lamp located in the operation panel.

When the ignition key is set to the "GLOW" position, it illuminates as the glow plug generates heat.

Illumination of the thermo-start lamp is controlled by the glow lamp timer, and the lamp is turned off after a specified amount of time passes.

The duration of illumination indicates an approximate period of time required for warm-up, and has been fixed at five seconds.

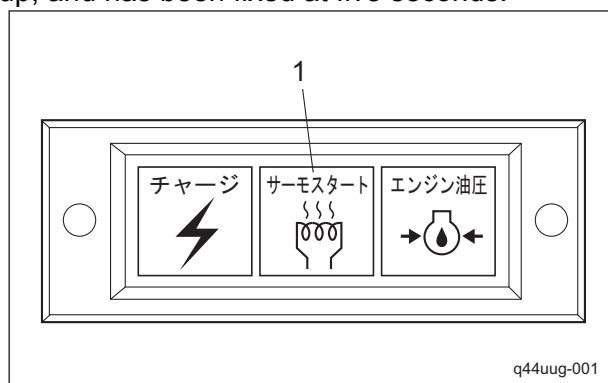

Thermo-start Lamp_001

Travel of Machine

Moving the Machine

1. Start the engine. (See "Procedure to Start Engine" (Page 4-19) .)
2. Raise all mower units, and then engage the mower lock levers for mower units #4 and #5.
3. Depress the brake pedal to release the parking brake.
4. Slowly depress the traveling pedal.
5. The machine will start to move.

Towing the Machine

If the machine does not travel due to engine trouble, etc., you can move it by towing it.

⚠ Caution

Tow the machine at a low speed while paying close attention.

Handling Instructions

⚠ Caution

Do not touch the unload valve except when towing the machine.

⚠ Caution

Before restarting the engine, be sure to close the unload valve.

1	Unload valve
---	--------------

6. Remove the wheel stopper, and then depress the brake pedal to release the parking brake.
7. Tow the machine slowly.

Cutting Work

Cutting Operation

⚠ Warning

Do NOT start to move or stop the machine abruptly. To do so is very dangerous. In addition, it may damage the hydraulic system or result in oil leakage.

⚠ Caution

Cutting work must be performed at an appropriate speed for the site and location. When cutting bumpy surfaces, keep the engine rpm steady, and slow down the cutting speed.

⚠ Caution

Knife rotation will be turned on or off based on the sensor-detected position of the mower units. Please note that if you stop operating the mower unit up/down lever before the mower units are raised completely, knife rotation may not stop.

1. Stop the engine. (See "Procedure to Stop Engine" (Page 4-20) .)
2. Apply the parking brake and chock the wheels.
3. Make sure that the steering wheel is raised completely, and then bring the seat to the backmost position.
4. Pull up the lever behind the seat to unlock it, and then tilt the seat forward to open the cover.

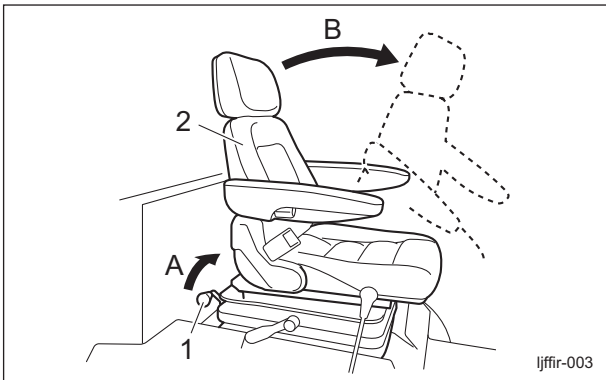

Towing the Machine_001

1	Lever
2	Seat
A	Pull up
B	Tilt forward

5. Turn the unload valve, located beside the hydraulic pump, 90 degrees (so that it is vertical) to open it.

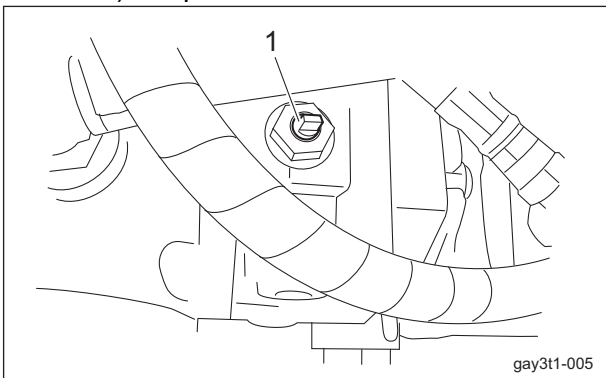

Towing the Machine_002

1. Start the engine. (See "Procedure to Start Engine" (Page 4-19) .)
2. Raise all mower units.
3. Depress the brake pedal to release the parking brake.
4. Shift the throttle lever to the rabbit icon (high speed) to run the engine at the maximum rpm.
5. Right before starting cutting work, release the mower lock levers for mower units #4 and #5.

Handling Instructions

6. Shift the mower unit up/down lever to the "DOWN" position to lower the mower units.

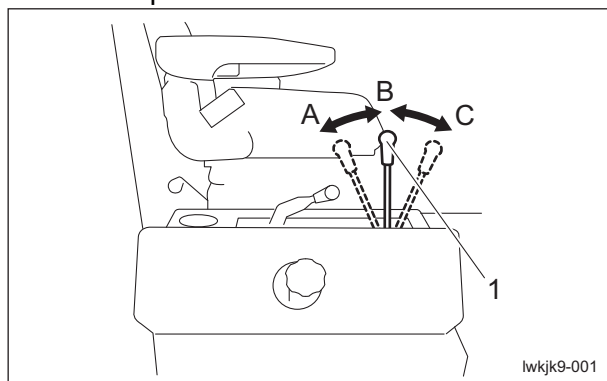

Cutting Operation_001

1	Mower unit up/down lever
A	UP
B	Neutral
C	DOWN

7. Set the knife rotation switch to the "ON" position to rotate the knives of all mower units.

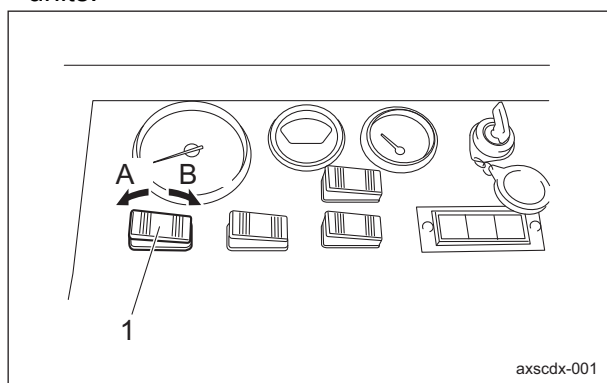

Cutting Operation_002

1	Knife rotation switch
A	ON
B	OFF

8. Depress the traveling pedal to start cutting work.

Note:

During the work, the knives will rotate or stop in sync with the up and down motion of the mower units.

Transporting

Transporting Procedure

When loading the machine into a trailer or a truck to transport it, drive the machine forward. When unloading, drive the machine in reverse. If the roof is installed on the machine, remove it. The roof may be damaged by wind pressure.

Handling Instructions

Maintenance Precautions.....	Page 5-2
Maintenance Schedule.....	Page 5-2
Specified Values.....	Page 5-4
Main Consumable Parts.....	Page 5-4
Jacking up the machine.....	Page 5-4
About the Jacking up the machine.....	Page 5-4
Jack-up Points.....	Page 5-4
Lubrication.....	Page 5-5
About the Lubrication.....	Page 5-5
Greasing Points.....	Page 5-6
Maintenance (Mower).....	Page 5-8
Change of Rotary Knife.....	Page 5-8
Sharpening of Rotary Knife.....	Page 5-12
Balancing of Rotary Knife.....	Page 5-13
Maintenance (Main Body).....	Page 5-14
Removing/Installing Tires.....	Page 5-14
Adjustment of Belt Tension.....	Page 5-15
Adjustment of Brake.....	Page 5-15
Adjusting the Neutral Position of the Piston Pump	Page 5-16
Change of Constant Velocity Joint.....	Page 5-17
Change of Fuse.....	Page 5-18
Long-Term Storage.....	Page 5-18
Before Long-Term Storage.....	Page 5-18

Maintenance

Maintenance Precautions

⚠ Caution

First, learn well the maintenance operations you plan to perform.

⚠ Caution

Use tools appropriate for each maintenance operation.

⚠ Caution

For the safe and best performance of your machine, use Baroness genuine parts for replacement and accessories.
Please note that our product warranty may be void if you use non-genuine parts for replacement or accessories.

Maintenance Schedule

Follow the maintenance schedule below.

- . . . Inspect, adjust, supply, clean
- . . . Replace (first time)
- △ . . . Replace

Maintenance Item		Before work	After work	Every 8 hrs.	Every 50 hrs.	Every 100 hrs.	Every 200 hrs.	Every 250 hrs.	Every 400 hrs.	Every 500 hrs.	Every year	Every 2 years	Every 4 years	Remarks
Engine	Tightening the parts	○												
	Fuel	○												
	Air cleaner	○					△							
	Engine oil	○		●	△									8 hrs (first time)
	Engine oil filter	○			●	△								50 hrs (first time)
	Ignition plug				○	△								
	Radiator	○												
	Oil cooler	○												
	Coolant	○			△									
	Fan belt	○									△			
	Battery	○										△		
	Battery fluid	○												
Cleaning the surface	○													

Maintenance

Maintenance Item		Before work	After work	Every 8 hrs.	Every 50 hrs.	Every 100 hrs.	Every 200 hrs.	Every 250 hrs.	Every 400 hrs.	Every 500 hrs.	Every year	Every 2 years	Every 4 years	Remarks	
Main body	Tightening the parts	○													
	Interlock system	○													
	Emergency switch	○													
	Electrical wiring										○				
	Knife	○													
	Steering chain	○													
	Cutting (or brush) height	○													
	Greasing, oiling				○										
	Tire	○													
	Rubber crawler	○													
	V-belt	○									△				
	Brake	○													
	Wire	○					△								
	Cover	○													
	Oil leakage	○													
	Hydraulic oil	○				●					△				100 hrs (first time)
	Hydraulic oil filter					●					△				100 hrs (first time)
	Hydraulic motor oil				●		△								50 hrs (first time)
	Power unit oil	○				●					△				100 hrs (first time)
	Transmission oil	○			●						△				50 hrs (first time)
	Hydraulic hose (moving part)	○											△		
	Hydraulic hose (fixed part)	○												△	
	Air cleaner	○					△								
Electromagnetic pump filter	○					△									
Fuel strainer					○					△					
Fuel pipe	○														
Cleaning the exterior	○														

The values for consumables are not guaranteed.
Replace the steering cylinder hoses every 2 years.

Maintenance

Specified Values

Fuel tank capacity	51.0 dm ³ (51.0 L)	
Hydraulic tank capacity	44.0 dm ³ (44.0 L)	Shell Tellus S2V46 or equivalent
Quantity of engine oil	9.7 dm ³ (9.7 L)	
Coolant volume	12.0 dm ³ (12.0 L)	Including reserve tank (1.0 L)
Front tires	150 kPa (1.5 kgf/cm ²)	29 × 14.00 - 15
Rear tires	140 kPa (1.4 kgf/cm ²)	20 × 12.00 - 10

Main Consumable Parts

Part Name	Code
Fan belt	PF17112-9701-0
Oil element	PF16414-3243-4
Air cleaner element	PFR1401-4227-0
Suction filter	K3413000040
Hydraulic cartridge filter	K3410000030
Hydraulic oil (20 L can)	K2913100200
Throttle wire	K1110168010
Brake wire, right	K1120238000
Brake wire, left	K1120205500
Rotary Knife	K253000009B

Jack-up Points

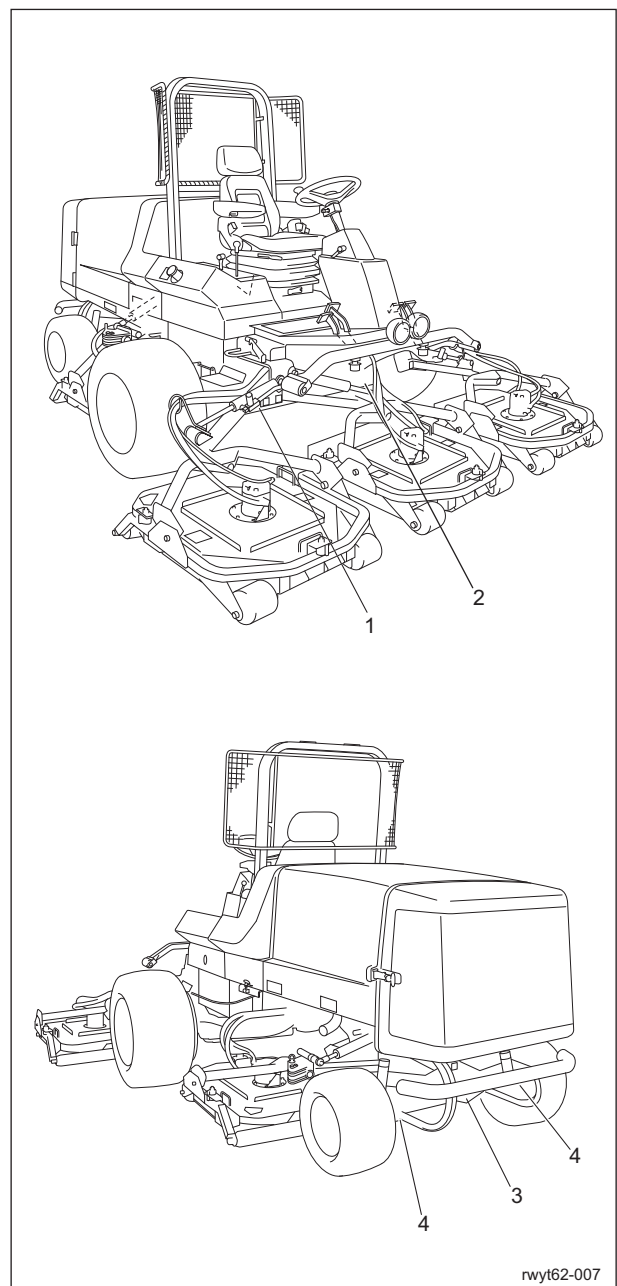

Jacking up the machine

About the Jacking up the machine

⚠ Warning

When replacing a tire or beginning any other maintenance or repairs, be sure to chock the wheels to prevent the machine from moving. Before jacking up the machine, park it on a hard, flat surface such as a concrete floor and remove any obstacles that could prevent you from performing the work safely. When necessary, use an appropriate chain block, hoist, or jack. Support the machine securely with jack stands or appropriate blocks. Failure to do so may cause the machine to move or fall, resulting in injury or death.

Use the jack-up points identified in this manual when jacking up the machine. Only place a jack under the jack-up points specified. Placing a jack at any other point could result in damage to the frame or other parts.

Jack-up Points_001

	Jack-up Points
1	Front right frame
2	Front left frame
3	Center of pivot
4	Below rear wheel motors

1. Front right frame

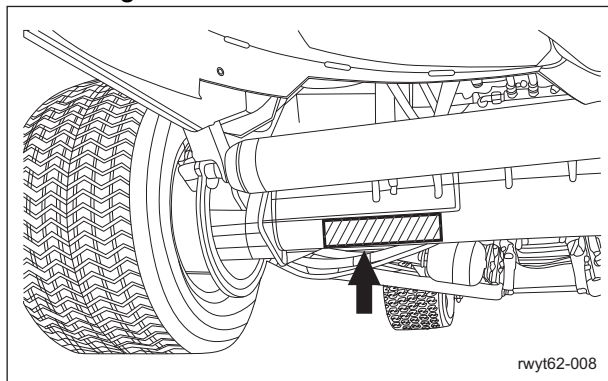

rwyf62-008

Jack-up Points_002

2. Front left frame

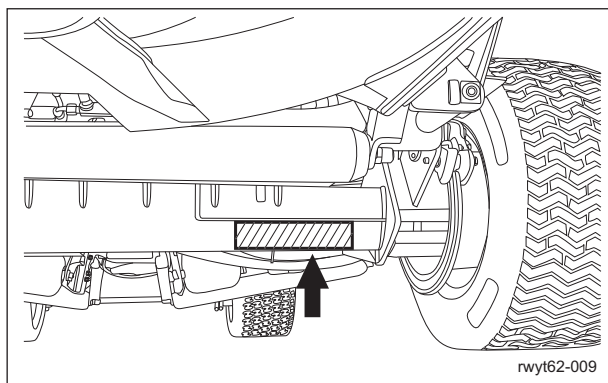

rwyf62-009

Jack-up Points_003

3. Center of pivot

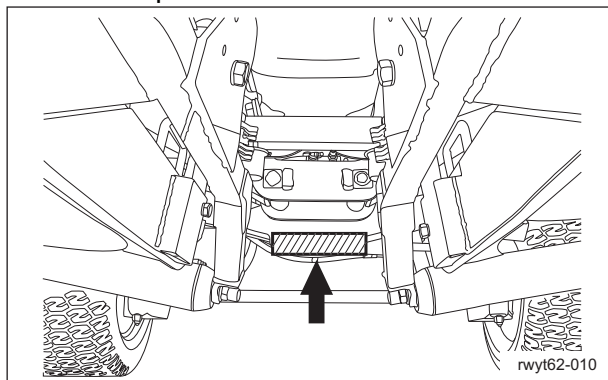

rwyf62-010

Jack-up Points_004

4. Below rear wheel motors Two locations

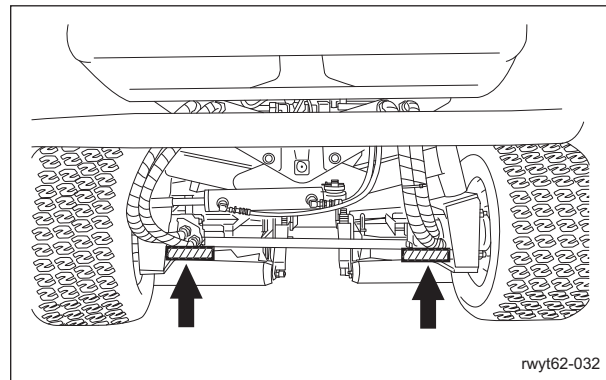

rwyf62-032

Jack-up Points_005

Lubrication

About the Lubrication

The moving parts of this machine need to be lubricated as a lack of grease on such parts could cause them to seize or be damaged. Grease the moving parts according to the maintenance schedule.

Maintenance

Greasing Points

Grease nipples are installed in the following locations.

Add grease every 50 hours of operation.

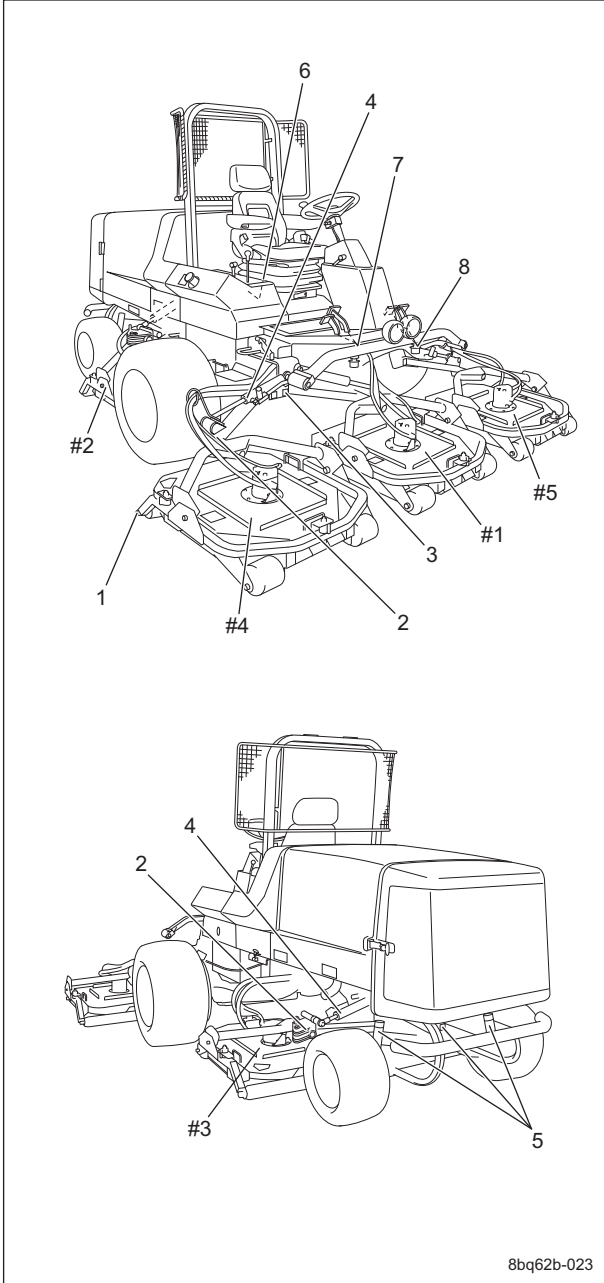

	Portion	No. of Greasing Points
1	Rear roller	10
2	Mower arm fulcrum	5
3	Lift arm fulcrum	5
4	Lift arm cylinder fulcrum	12
5	Pivot	3
6	Neutral position area	2
7	Traveling pedal shaft fulcrum	2
8	Foot brake	3

1. Rear roller

There is one greasing point each on the left and right of each mower unit.

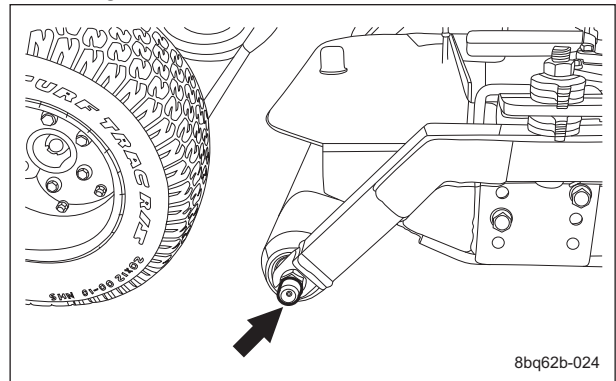

Greasing Points_002

2. Mower arm fulcrum

There is one greasing point on the arm connected to each mower unit.

Mower units #1, #4 and #5

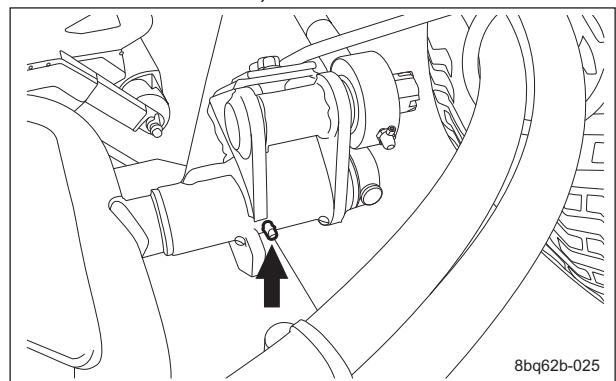

Greasing Points_003

Mower units #2 and #3

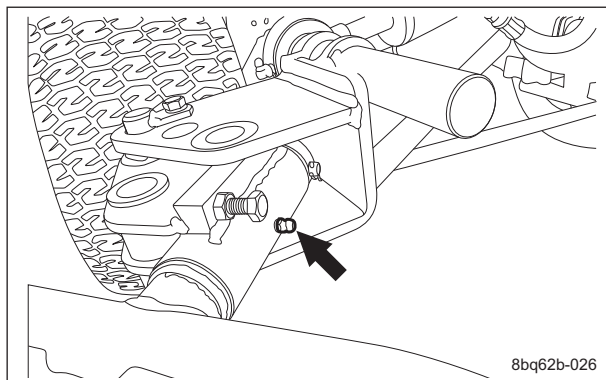

8bq62b-026

Greasing Points_004

3. Lift arm fulcrum

There is one greasing point on the arm connected to each mower unit. Lower the mower units before greasing the lift arm fulcrums.

Mower units #1 and #4

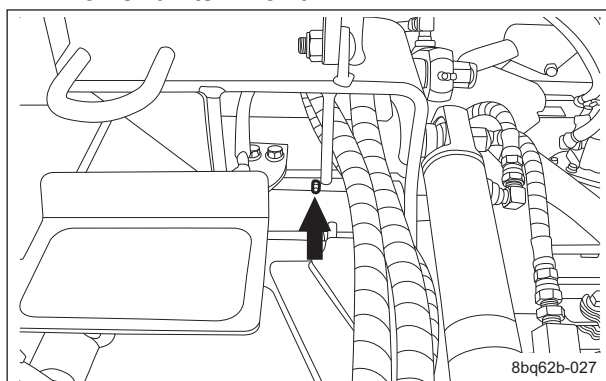

8bq62b-027

Greasing Points_005

Mower units #2 and #3

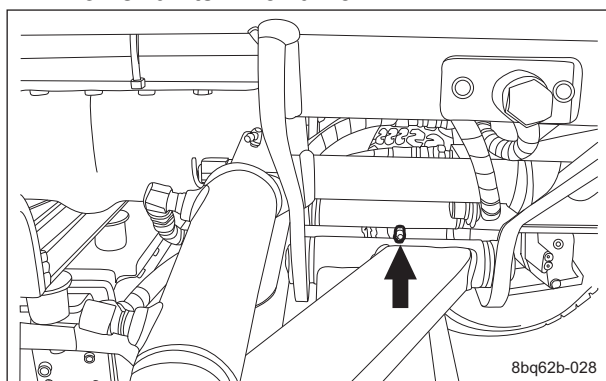

8bq62b-028

Greasing Points_006

Mower unit #5

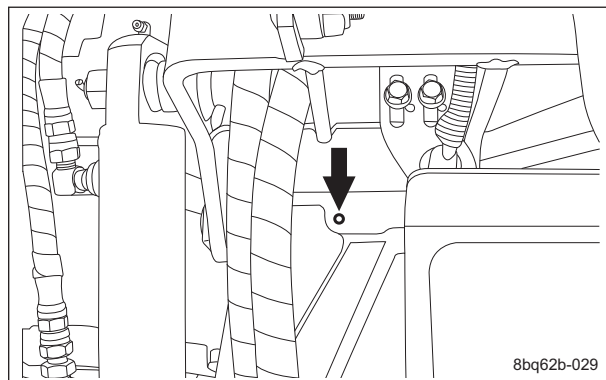

8bq62b-029

Greasing Points_007

4. Lift arm cylinder fulcrum

This is on each cylinder of the arms connected to each mower unit.

Mower units #1, #4 and #5

There are two greasing points on each cylinder.

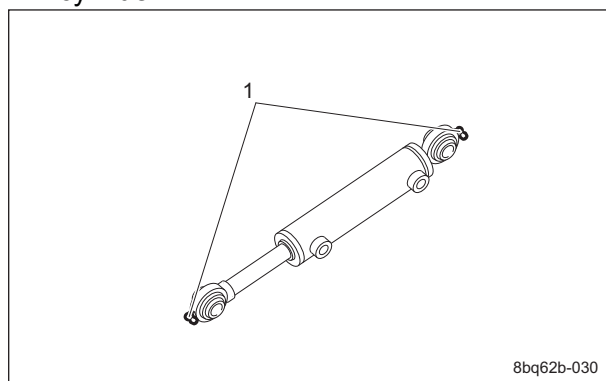

8bq62b-030

Greasing Points_008

1	Grease nipple (2 locations)
---	-----------------------------

Mower units #2 and #3

There are three greasing points on each cylinder.

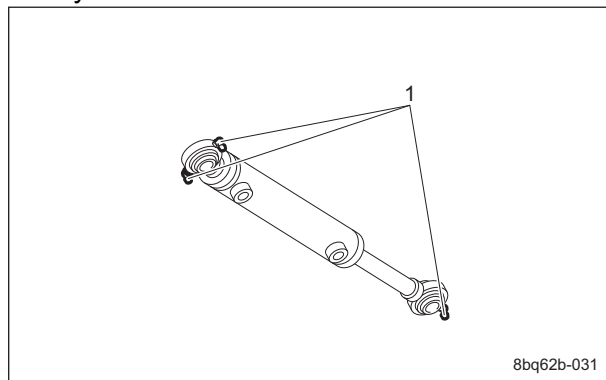

8bq62b-031

Greasing Points_009

1	Grease nipple (3 locations)
---	-----------------------------

Maintenance

5. Pivot

Middle between the rear wheels

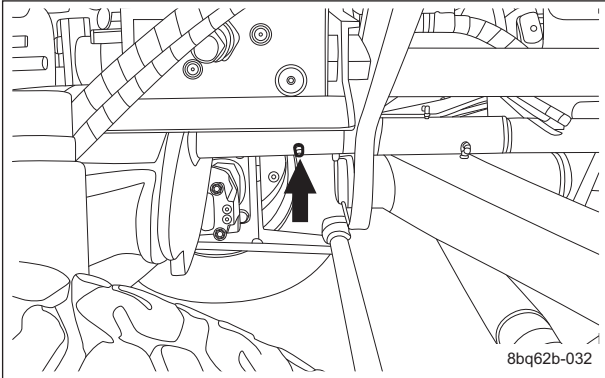

Greasing Points_010

Rear left wheel

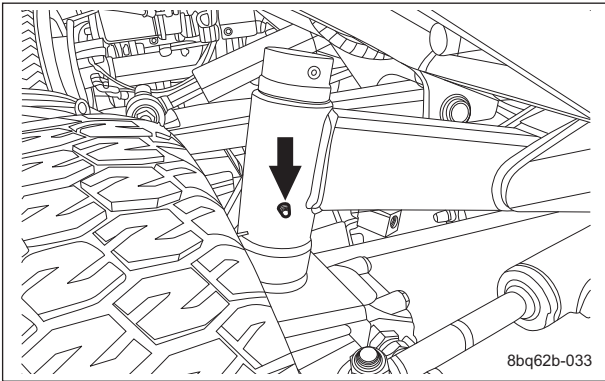

Greasing Points_011

Rear right wheel

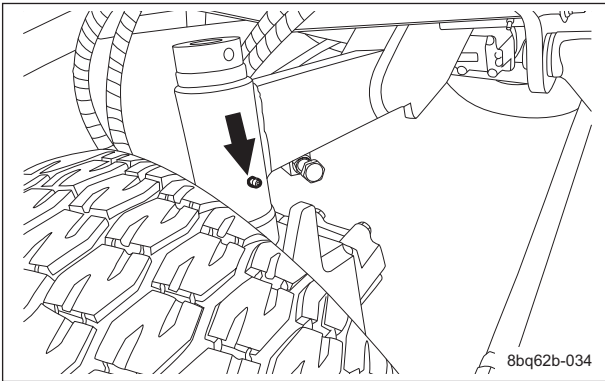

Greasing Points_012

6. Neutral position area

There are two locations.

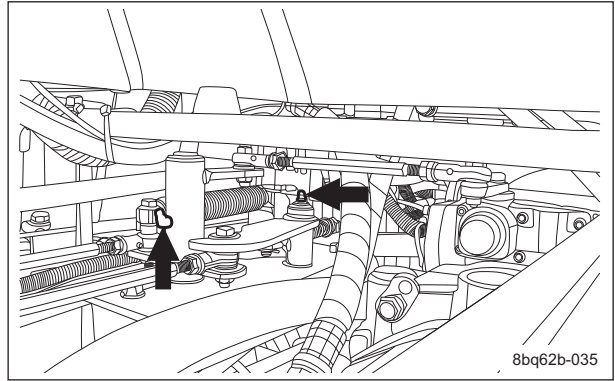

Greasing Points_013

7. Traveling pedal shaft fulcrum

There are two locations.

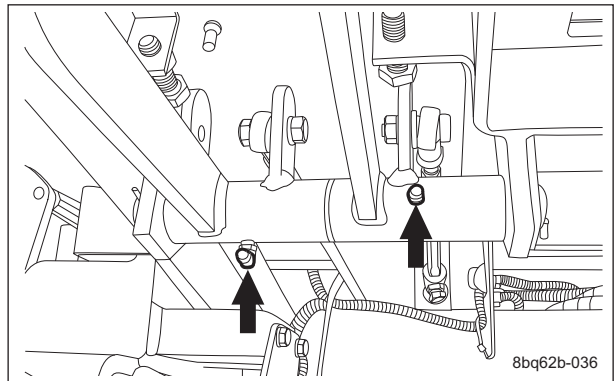

Greasing Points_014

8. Foot brake

There are three locations.

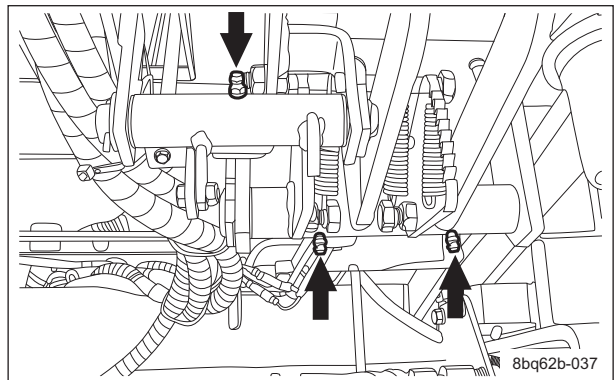

Greasing Points_015

Maintenance (Mower)

Change of Rotary Knife

⚠ Danger

The rotary knife is an edged tool. Handle them carefully, since they could cut your hands or legs.

! Danger

If the rotary knife becomes worn or damaged, a crack or tear between the sail and flat part will result.

Since a piece of the rotary knife may break and fly off while it is rotating, be extremely careful.

! Caution

When touching edged tools, wear gloves, since they could cut your hands.

! Caution

The rotary knife has a specific installation direction. Do not install the rotary knife facing the wrong direction.

Important

Before installing the rotary knife, make sure that it is balanced.

Important

The tightening torque for the knife mounting bolt is 67 - 85 N-m (683.20 - 866.75 kgf-cm).

If the edge of the rotary knife becomes chipped or thin, replace it with a new one.

The standard for replacing the rotary knife is described below.

1. When there is a sharpening margin of less than 2/3 of the total rotary knife width

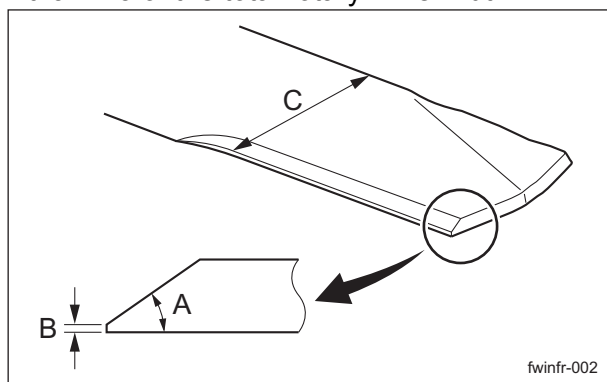

Change of Rotary Knife_001

A	30 - 40°
B	0.5 - 1.0 mm
C	2/3 or more

2. When the edge thickness is less than 1/3 of the total thickness

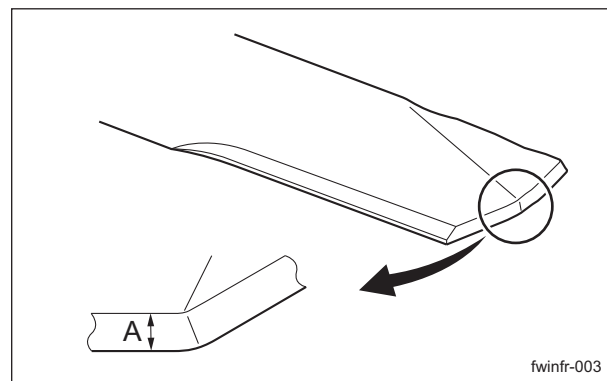

Change of Rotary Knife_002

A	1/3 or more
---	-------------

Mower unit #1

1. Start the engine, and then raise the mower units.
2. Stop the engine, and then remove the key.
3. Lift the mower unit at the front.

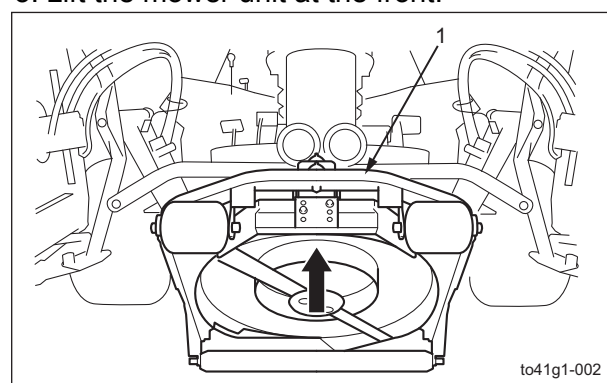

Mower unit #1_001

1	Mower unit
---	------------

4. Remove the cotter pin and hardened roundhead pin inserted at a, and then insert them at b.

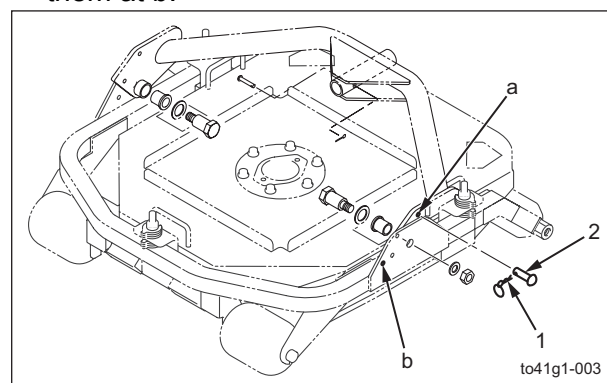

Mower unit #1_002

Maintenance

1	Cotter pin
2	Hardened roundhead pin

5. Follow the steps below to remove the rotary knife.

- [1] Use the square pipe from the included tools to secure the rotary knife so that it does not turn.
- [2] Remove the two bolts, spring washers and washers used to install the rotary knife.
- [3] Remove the knife guide.
- [4] Remove the rotary knife.

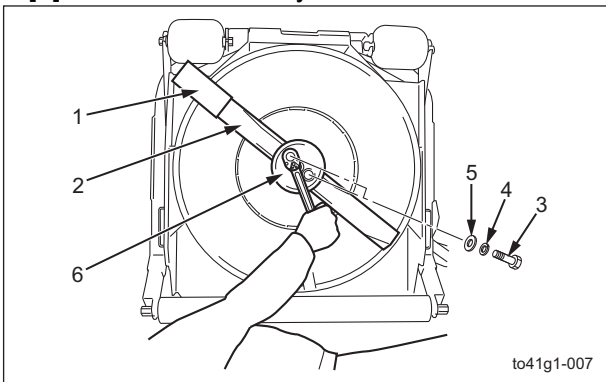

Mower unit #1_003

1	Square pipe
2	Rotary knife
3	Bolt
4	Spring washer
5	Washer
6	Knife guide

6. Install the rotary knife.
For installing the rotary knife, reverse the removing procedure.

Mower Units #2/#3

1. Remove the clip pin installed on the mower arm, and then pull out the grip pin.

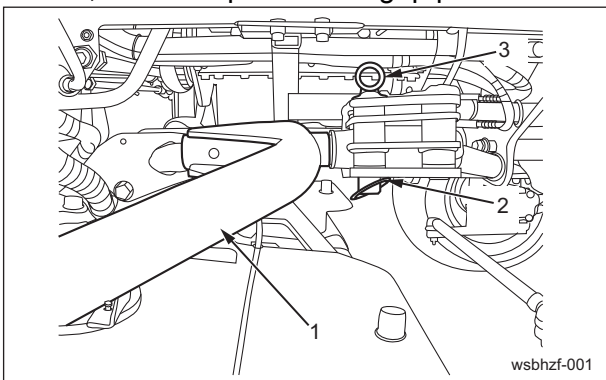

Mower Units #2/#3_001

1	Mower arm
2	Clip pin
3	Grip pin

2. Pull out the mower deck.

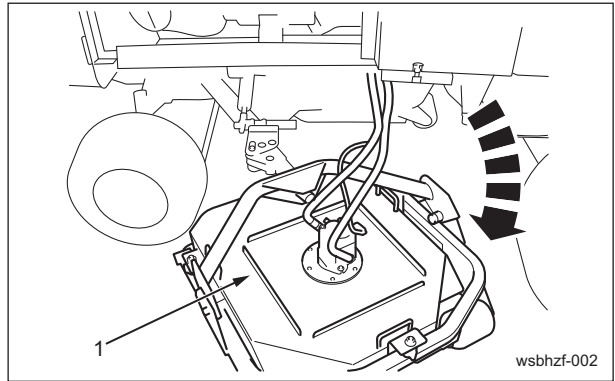

Mower Units #2/#3_002

1	Mower unit
---	------------

3. Install the grip pin and clip pin in the mounting hole for maintenance.

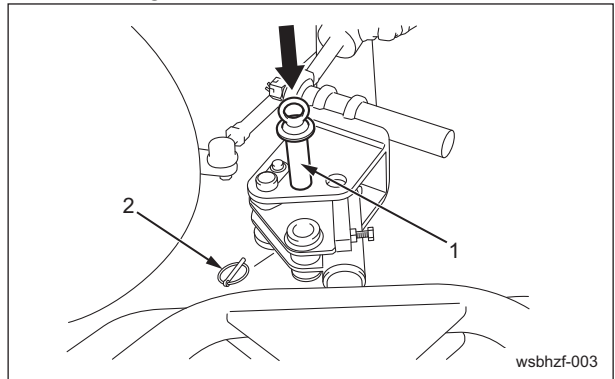

Mower Units #2/#3_003

1	Grip pin
2	Clip pin

- 4. Start the engine, and then raise the mower units.
- 5. Stop the engine, and then remove the key.
- 6. Lift the mower unit at the front.

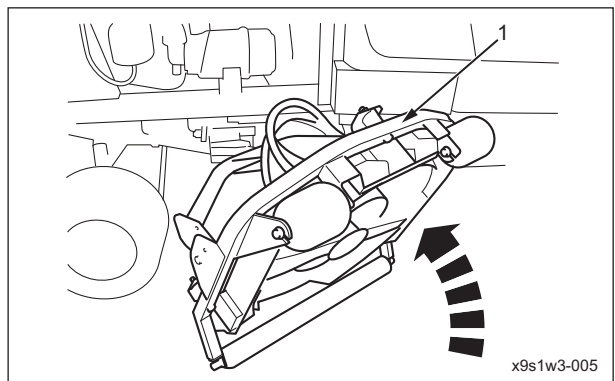

Mower Units #2/#3_004

1	Mower unit
---	------------

7. Remove the cotter pin and hardened roundhead pin inserted at a, and then insert them at b.

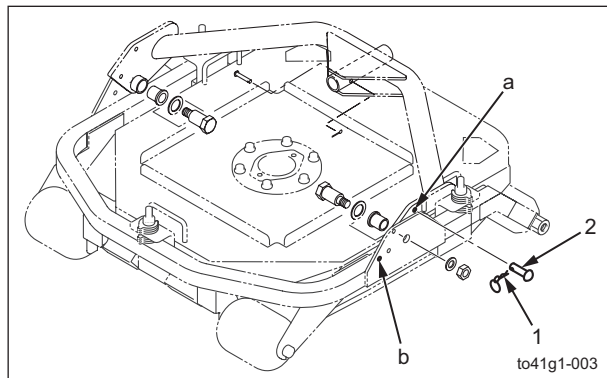

Mower Units #2/#3_005

1	Cotter pin
2	Hardened roundhead pin

8. Follow the steps below to remove the rotary knife.

- [1] Use the square pipe from the included tools to secure the rotary knife so that it does not turn.
- [2] Remove the two bolts, spring washers and washers used to install the rotary knife.
- [3] Remove the knife guide.
- [4] Remove the rotary knife.

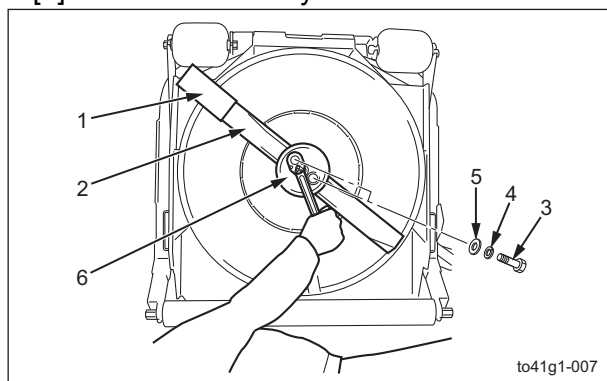

Deck #2/#3_006

1	Square pipe
2	Rotary knife
3	Bolt
4	Spring washer
5	Washer
6	Knife guide

9. Install the rotary knife.
For installing the rotary knife, reverse the removing procedure.

Mower Units #4/#5

1. Start the engine, and then raise the mower units.

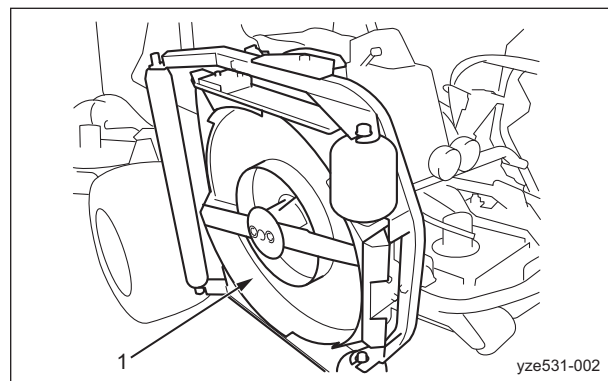

Mower Units #4/#5_001

1	Mower unit
---	------------

2. Stop the engine, and then remove the key.
3. Remove the cotter pin and hardened roundhead pin inserted at a, and then insert them at b.

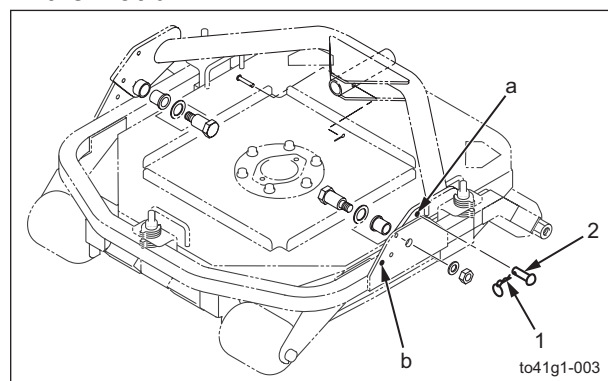

Mower Units #4/#5_002

1	Cotter pin
2	Hardened roundhead pin

4. Follow the steps below to remove the rotary knife.

- [1] Use the square pipe from the included tools to secure the rotary knife so that it does not turn.
- [2] Remove the two bolts, spring washers and washers used to install the rotary knife.
- [3] Remove the knife guide.

Maintenance

[4] Remove the rotary knife.

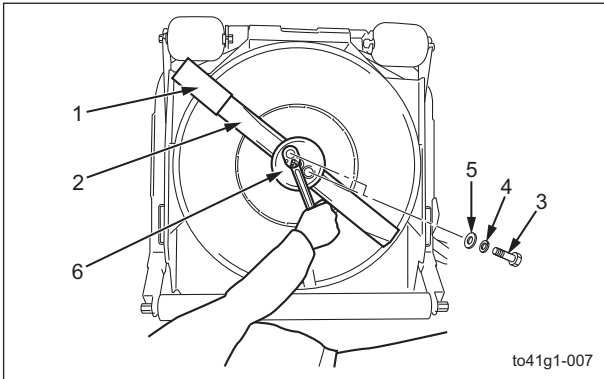

Mower Units #4/#5_003

1	Square pipe
2	Rotary knife
3	Bolt
4	Spring washer
5	Washer
6	Knife guide

5. Install the rotary knife.

For installing the rotary knife, reverse the removing procedure.

Sharpening of Rotary Knife

⚠ Danger

The rotary knife is an edged tool. Handle them carefully, since they could cut your hands or legs.

⚠ Danger

If the rotary knife becomes worn or damaged, a crack or tear between the sail and flat part will result. Since a piece of the rotary knife may break and fly off while it is rotating, be extremely careful.

⚠ Warning

Using an imbalanced rotary knife may cause vibrations, resulting in damage to the machine.

⚠ Caution

When sharpening the rotary knife, be sure to wear safety glasses and gloves.

When the edge of the rotary knife becomes rounded and no longer cuts well, sharpen the rotary knife by grinding the cutting edge with a grinder or sander.

If the edge of the rotary knife becomes chipped or thin, replace it with a new one.

The standard for sharpening the rotary knife is described below.

- When there is a sharpening margin of 2/3 or more of the total rotary knife width

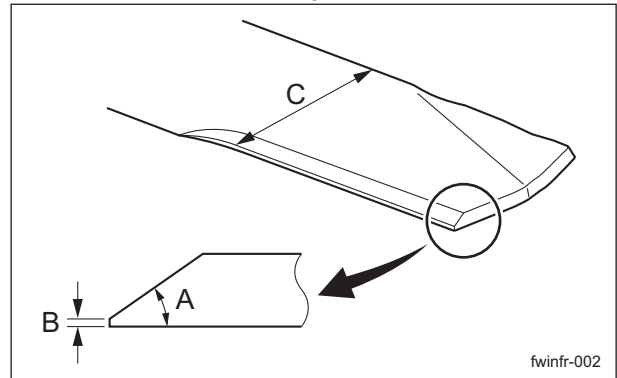

Sharpening of Rotary Knife_001

A	30 - 40°
B	0.5 - 1.0 mm
C	2/3 or more

- When the edge thickness is 1/3 or more of the total thickness

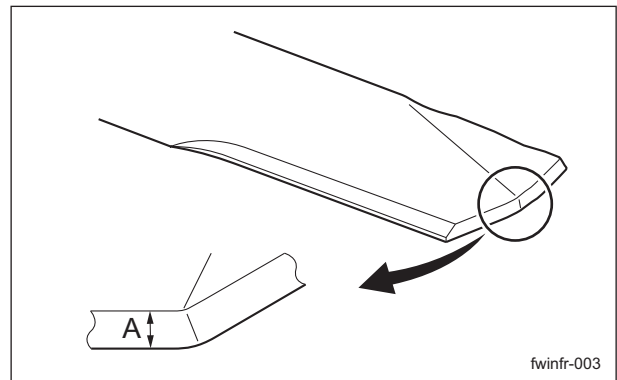

Sharpening of Rotary Knife_002

A	1/3 or more
---	-------------

Follow the steps below to sharpen the rotary knife.

1. Remove the rotary knife from the machine.
(See .)

Important

Sharpen only the top surface of the edge, and be sure to maintain the original angle. By equally grinding the left and right ends of the rotary knife, it can be sharpened without becoming imbalanced.

2. Sharpen the rotary knife by sharpening the edge with a grinder.
3. The edge angle should be 30 - 40 degrees, and the point thickness should be 0.5 - 1.0 mm.

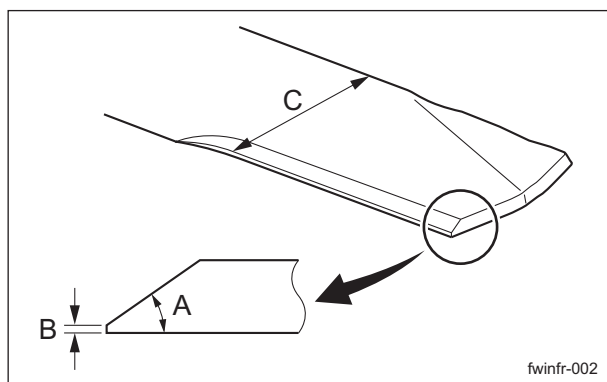

Sharpening of Rotary Knife_003

A	30 - 40°
B	0.5 - 1.0 mm
C	2/3 or more

4. Balance the rotary knife. (See "Balancing of Rotary Knife" (Page 5-13) .)
5. If it is not balanced, repeat steps 2. - 4.

Balancing of Rotary Knife

! Danger

The rotary knife is an edged tool. Handle them carefully, since they could cut your hands or legs.

! Danger

Using an imbalanced rotary knife may cause vibrations, resulting in damage to the machine.

! Caution

When touching edged tools, wear gloves, since they could cut your hands.

When the rotary knife is worn asymmetrically, causing vibrations, or when it becomes dull or worn, remove the rotary knife from the machine and balance it.

Follow the steps below to balance the rotary knife.

1. Remove the rotary knife from the machine.
(See .)
2. Balance the rotary knife using either of the following methods.

[1] Install the balancer equipment in an appropriate location.

Fit the hole at the center of the rotary knife onto the balancer equipment, and then balance the left and right ends so that the rotary knife is level.

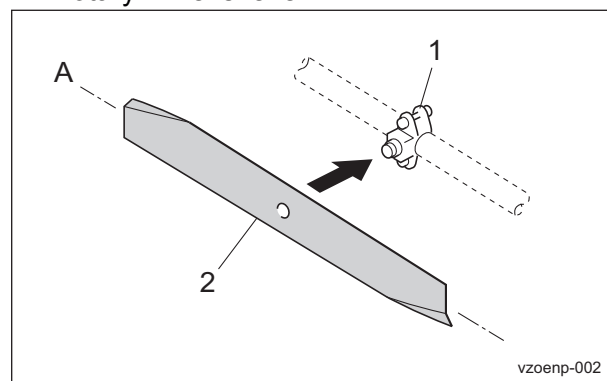

Balancing of Rotary Knife_001

1	Balancer equipment
2	Rotary knife
A	Level

Maintenance

[2] If the balancer equipment is not available, insert a screwdriver into the hole at the center of the rotary knife, and then balance the left and right ends so that the rotary knife is level.

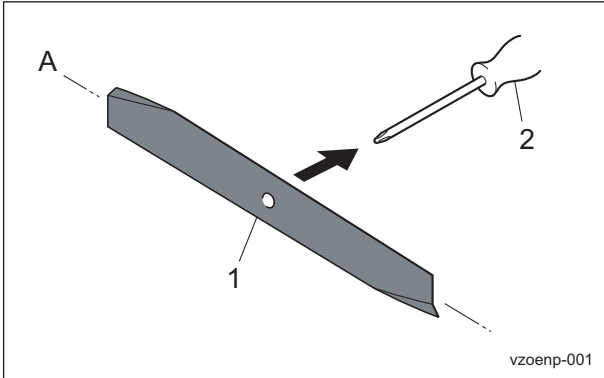

Balancing of Rotary Knife_002

1	Rotary knife
2	Screwdriver
A	Level

Maintenance (Main Body)

Removing/Installing Tires

Front Tires

Follow the steps below to remove the front tires:

1. Loosen the bolts.

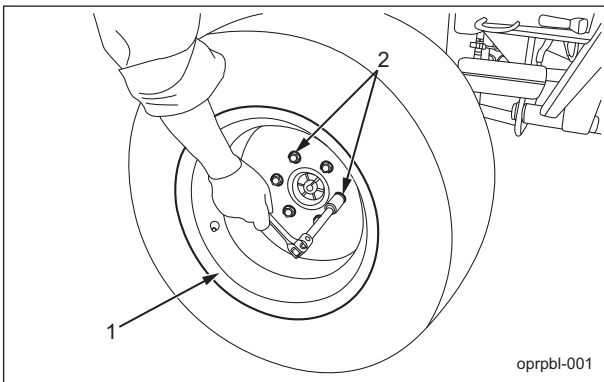

Front Tires_001

1	Front tire
2	Heat-treated bolt

2. Securely place the jack beneath the jack-up point of the front left/right frame area, and then raise it until the tire lifts off the ground. (See "Jack-up Points" (Page 5-4) .)
3. Remove the bolts.
4. Remove the tire from the wheel mounting seat.

Caution

Refer to the Tightening Torque table. Note that the Baroness product warranty may not apply to defects caused by incorrect or overtorque tightening etc.

Important

Tighten the bolts in the tightening order (crosswise).

For installing the front tires, reverse the removing procedure.

Rear Tires

Follow the steps below to remove the rear tires:

1. Loosen the bolts.

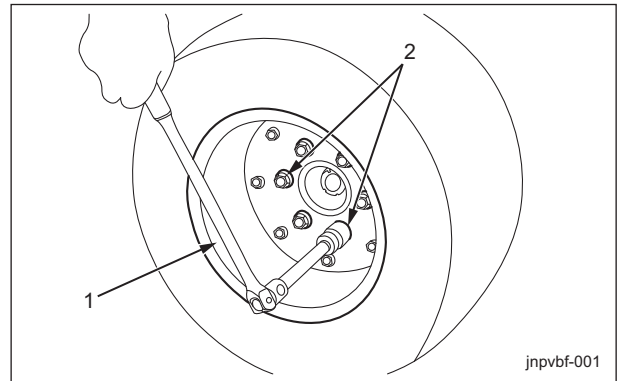

Rear Tires_001

1	Rear tire
2	Heat-treated bolt

2. Securely place the jack beneath the jack-up point of the rear left/right frame area, and then raise it until the tire lifts off the ground. (See "Jack-up Points" (Page 5-4) .)
3. Remove the bolts.
4. Remove the tire from the wheel mounting seat.

Caution

Refer to the Tightening Torque table. Note that the Baroness product warranty may not apply to defects caused by incorrect or overtorque tightening.

Important

Tighten the bolts in the tightening order (crosswise).

For installing the rear tires, reverse the removing procedure.

Adjustment of Belt Tension

Caution

Be sure to stop the engine before adjusting the belts.

If the belt becomes slack due to frequent use, it may jump or slip. In addition, if it is overtightened, it may wear prematurely. If necessary, adjust it, and always check the belt for appropriate tension.

Fan Belt

Caution

Be sure to stop the engine before adjusting the belts.

For details on handling the engine, please refer to the separate Engine Operating Manual.

1. Press the middle of the belt with your finger to check the belt tension.
2. If the belt is too slack, loosen bolts A and B (that affix the alternator), and then move the alternator to adjust the tension.

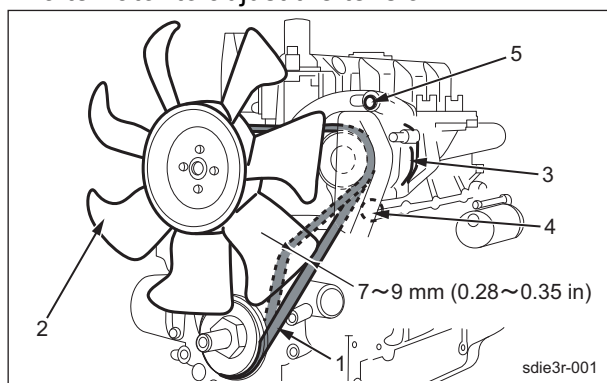

Fan Belt_001

1	Fan belt
2	Blade
3	Alternator
4	Bolt A
5	Bolt B

Adjustment of Brake

Danger

Make sure that the brake wire is not cracked or damaged.

Danger

If the brake is not sufficiently effective, adjust the brake pad clearance.

Important

Adjust the brake with the brake pads.

The brake pad wear limit is 3.0 mm (0.12 in).

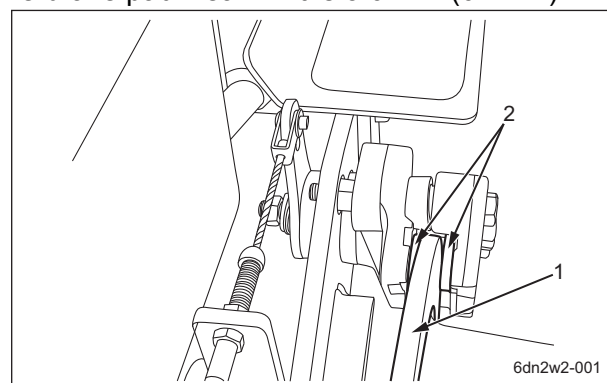

Adjustment of Brake_001

1	Disc
2	Brake pad

Caution

Make sure that the lever is maintained in the open position (neutral).

1. For each wheel, fully tighten the adjustment bolt on the brake disc side.

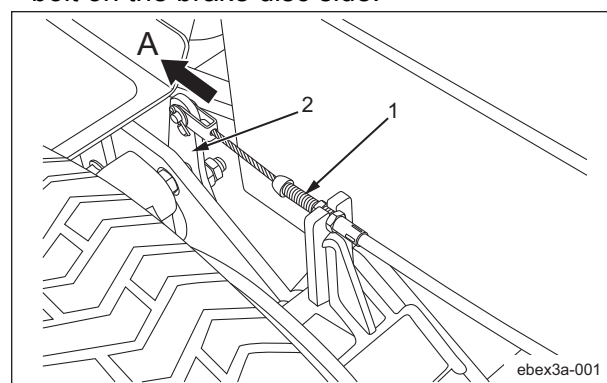

Adjustment of Brake_002

Maintenance

1	Adjustment bolt (on brake disc side)
2	Lever
A	Open (neutral)

2. Reduce the clearance by loosening the lock nut, then tightening the adjustment nut. Tighten the adjustment nut until the friction material contacts the friction surface of the disc.

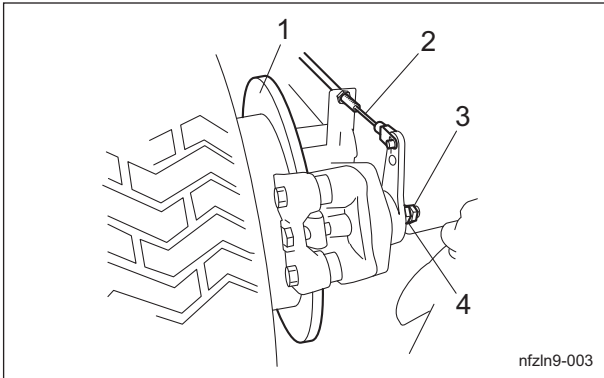

Adjustment of Brake_003

1	Brake disc
2	Wire
3	Lock nut
4	Adjustment nut

⚠ Danger

A clearance that is too small may result in heat generation or fire.

3. Loosen the adjustment nut, adjust the clearance to about 0.2 mm, and then check that the disc rotates freely.
4. Tighten the lock nut, and then fully tighten it while holding the adjustment nut in place.
5. With the brake pedal released, obtain a play of 1.0 mm (0.039 in) at the connection of the pedal and inner wire.

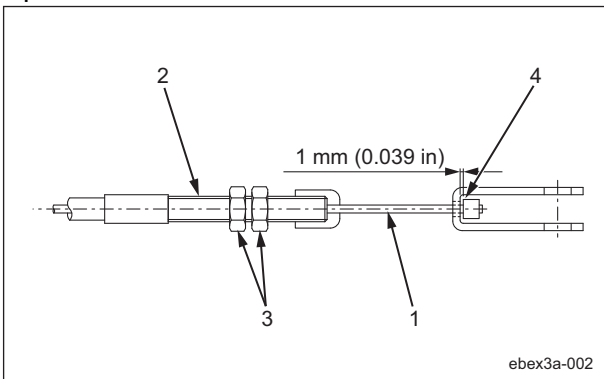

Adjustment of Brake_004

1	Inner wire
2	Adjustment bolt
3	Brake wire (outer)
4	Connection

6. Use a wrench to loosen the adjustment bolt and tighten it after making the adjustment.
7. Link the left and right brake pedals.
8. Start the engine and drive to check the following.
 - Make sure that heat is not generated in the brake area.
 - Make sure that the left and right brakes are equally effective.

⚠ Danger

It would be extremely dangerous and may result in an unexpected accident if the left and right brakes are not equally effective.

9. If the left and right brakes are not equally effective, make fine adjustments with the adjustment bolt on the brake wire.

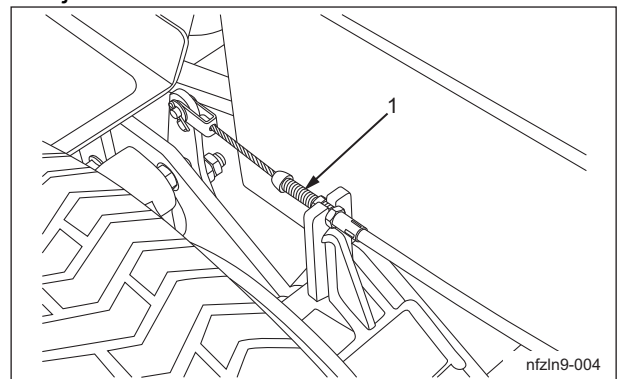

Adjustment of Brake_005

1	Adjustment bolt (on brake disc side)
---	--------------------------------------

Break-in of Brakes

If the brake shoes or brake pads are worn, replace them with new ones. Immediately after replacement, drive to break in the brakes if the effectiveness of the brakes is low. While driving, lightly operate the brakes to break in the contact areas.

Adjusting the Neutral Position of the Piston Pump

⚠ Caution

Make sure not to touch rotating tires.

If the machine moves forward or backward while the traveling pedals are released, they are not set to the neutral position.

Follow the steps below to make adjustments.

1. Stop the engine.
2. Place the jacks beneath the jack-up points, and then lift the machine off the ground. Use stable jack stands, and raise the machine until the tires lift off the ground. (See "Jack-up Points" (Page 5-4) .)
3. Pull up the seat lever, and then slide the seat back completely.

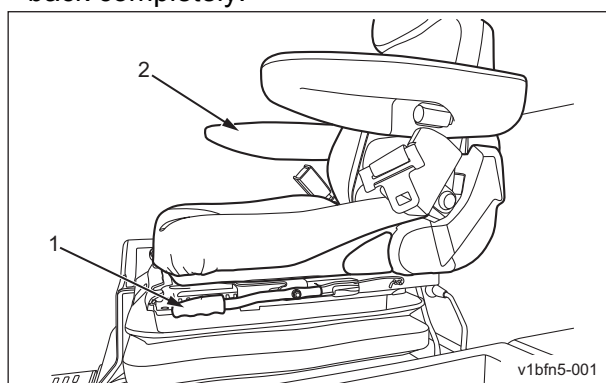

Adjusting the Neutral Position of the Piston Pump_001

1	Seat lever
2	Seat

4. While pulling up the seat lever, tilt the seat forward.

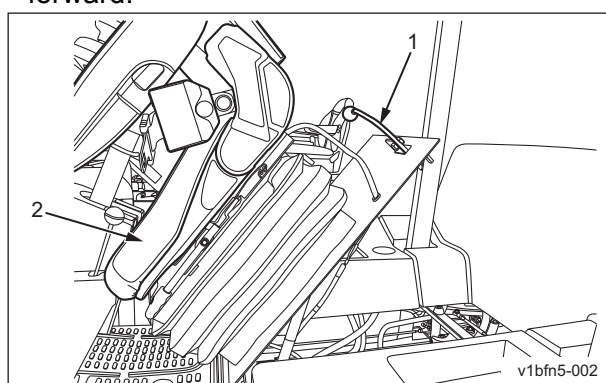

Adjusting the Neutral Position of the Piston Pump_002

1	Seat lever
2	Seat

5. Start the engine, and rev it up to the maximum rpm.
6. Set the 2WD/4WD Selector Switch to the "2WD" position.
7. Adjust the neutral position.

[1] If the front tires rotate forward, loosen the lock nuts, and then turn the neutral adjustment rod to shorten it.

[2] If the front tires rotate in reverse, loosen the lock nuts, and then turn the neutral adjustment rod to extend it.

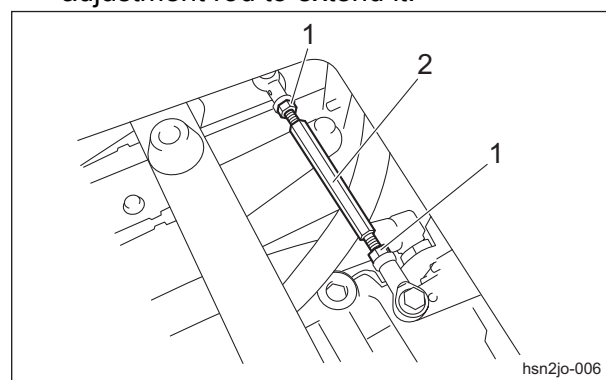

Adjusting the Neutral Position of the Piston Pump_003

1	Lock nut
2	Neutral adjustment rod

8. Find the position where the front wheels stop, and then tighten the lock nuts.

Change of Constant Velocity Joint

Caution

Do not use any other grease than the grease for the NTN constant velocity joint.

If grease leaks from the joint and attaching portion or boot band attaching portion, replace the boot and O-ring etc.

You cannot reuse the boot band. Be sure to replace it with a new one.

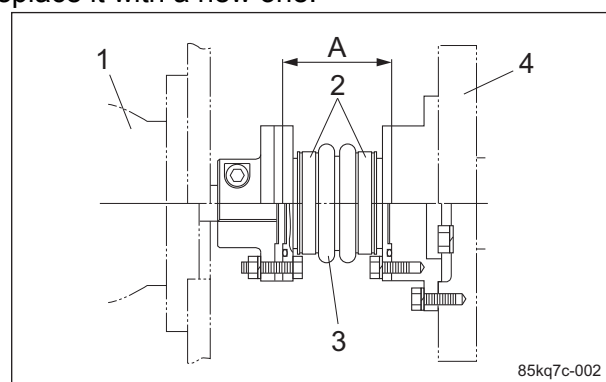

Change of Constant Velocity Joint_001

1	Hydraulic pump
2	Boot band
3	Boot
4	Engine
A	82 - 86 mm

Maintenance

Change of Fuse

Fuse Box

The fuse box includes spare fuses and tools.

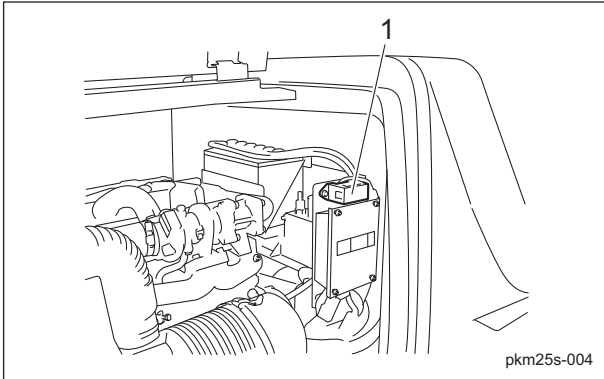

Fuse Box_001

1	Fuse box
---	----------

The machine uses a mini fuse for automobiles. Replace an old fuse with a new fuse of the specified capacity.

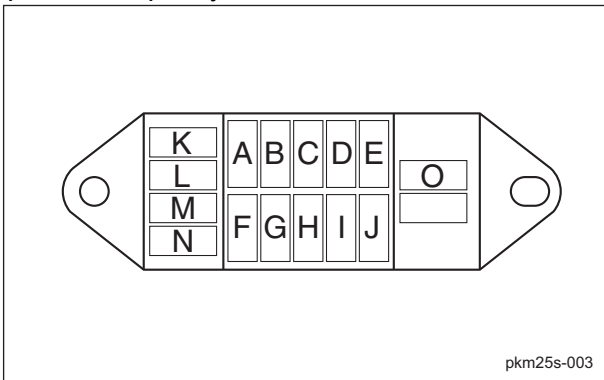

Fuse Box_002

A	5 A	Timer
B	5 A	Thermo-start lamp
C	5 A	Tachometer, fuel gauge, water temperature gauge, charge lamp, oil pressure (engine oil pressure) lamp, water temperature buzzer, hydraulic oil buzzer
D	15 A	Relay box 1, differential lock, (assist switch)
E	15 A	Relay box 2, 2WD/4WD selection, #4/#5 proximity switches
F	-	-
G	5 A	Timer
H	5 A	Alternator
I	5 A	Fuel pump, safety relay, stop solenoid
J	5 A	Relay (starter)
K	5 A	Spare
L	5 A	
M	15 A	
N	15 A	
O		Fuse removal tool

Fusible Link

Fuse capacity of the fusible link is 50 A.

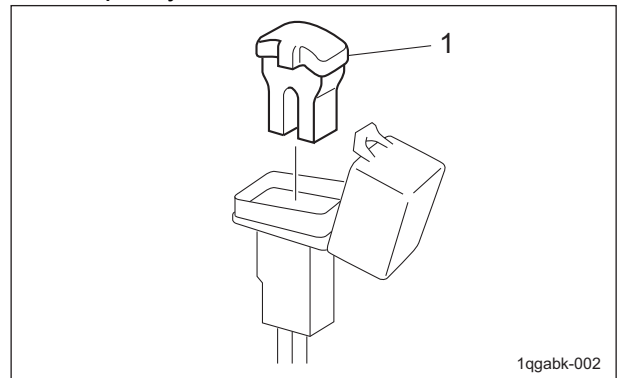

Fusible Link_001

1	Fusible link
---	--------------

Long-Term Storage

Before Long-Term Storage

- Remove any dirt, grass, debris, or oil stains completely.
- Supply oil and apply grease to appropriate parts.
- Remove the battery.

EC Declaration of Conformity

We

Manufacture's Name: Kyoisha Co., Ltd.
Manufacture's Address: 1-26 Miyuki-cho, Toyokawa, Aichi-pref. 442-8530 Japan

declare that

Product: Ride-on Lawnmower
Make: BARONESS
Type: GM2800B
Starting Serial No.: 10021

compiler of the technical file

Name: Kyoisha U.K.Ltd.
Address: Unit 5 Hatch Industrial Park Grewell Road, Basingstoke
Hampshire RG24 7NG, the United Kingdom

in accordance with the following Directives :

2006/42/EC The Machinery Directive and its amending directives

has been designed and manufactured using the following specifications :

ISO12100 : 2010
EN836 : 1997
ISO5395 : 1990

References of other Community Directives applied

2000/14/EC , 2004/108/EC

Place: Japan
Date : January 10, 2012

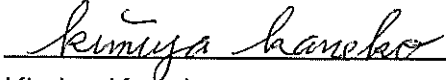
Signature : 
Name : Kimiya Kaneko
Position : Quality Dept. Manager

Manufacturer's Declaration of Conformity for

Product Identification

Product : Ride-on lawnmower
Make : BARONESS
Type : GM2800
Version(s) : B
Starting Serial No. : 10021
Measured Sound Power Level : LWA 103.35 dB
Guaranteed Sound Power Level : LWA 105 dB
Manufacturer
Name : Kyoisha Co., Ltd.
Address : 1-26 Miyuki-cho, Toyokawa, Aichi-pref.,
Japan

Technical Documentation

Keeper's Name : Kyoisha Co., Ltd.
Keeper's Address : 1-26 Miyuki-cho, Toyokawa, Aichi-pref.,
Japan

Conformity Assessment Procedure : Internal Control of Production with Assessment of
Technical Documentation and Periodical Checking
(Annex VI) of 2000/14/EC-2005/88/EC

Involved Notified Body

Name : SNCH
Address : 11, Route de Sandweiler
5230 Sandweiler
Luxembourg

Technical Construction File

Date : December 15,2011
Technical Construction File No. : TCGM2800-00
Test Laboratory : TUV Rheinland Luxemburg GmbH
2a, Kalchesbruck
L-1852 Luxembourg

Certificate / Report No. : SNCH*2000/14*2005/88*1983*00/TCGM2800-00

Means of conformity

The product is in conformity with the Directive relating to the noise emission in the environment by
equipment for use outdoors 2000/14/EC-2005/88/EC, in accordance with Article 12 of the Directive.

References of other Community Directives applied

2006/42/EC , 2004/108/EC

Signature :



Kimiya Kaneko
Manager
Quality Dept.
Kyoisha Co., Ltd.

Date : January 10,2012

BARONESS[®]
Quality on Demand

 **KYOEISHA CO., LTD.**
Head Office 1-26, Miyuki-cho, Tyokawa, Tel : (0533) 84-1390
Aichi-Pref.442-8530 Japan. Fax : (0533) 89-3623